



CABLE CARRIERS

for □-Track



Contents

General Information		3
Questionnaire		4
S 1 Track & Accessories		5 – 9
LS 1 Cable carriers & Accessories		
– Polyamid type –		10
S 1 Cable carriers & Accessories		
– Polyamid swivel type –		11
S 1 Cable carriers & Accessories		
– Steel type –		12 – 14
S 1 Cable carriers & Accessories		
– Steel type –		15, 16
S 1 Cable carriers & Accessories		
– Steel type for round cables & hoses		17
S 1 Control carriers & Accessories		18, 19
S 2 Track & Accessories		20 – 23
S 2 Cable carriers & Accessories		
– Steel type –		24
S 2 Cable carriers & Accessories		
– Steel type –		25
S 2 Cable carriers & Accessories		
– Steel type –		26, 27, 28
S 2 Cable carriers & Accessories		
– Stainless Steel type –		29
S 2 Cable carriers & Accessories		
– Steel type for round cables & hoses		30
S 2 Control carriers & Accessories		31, 32
S 2 Control carriers with motorized lifting device for pushbuttons		33
S 2 Control carriers installation information		34
S 3 Track & Accessories		35
S 3 Cable carriers & Accessories		
– Steel type –		36
K 1 Track & Accessories		37, 38
K 1 Cable carriers & Accessories		39
K 1 Accessories & Control carriers		40
K 1 Cable carriers & Accessories		41
Chains and ropes for cable tension relief		42
Typical Applications and How to Order		43 – 45
System Layout		46
Support Spacing for Box Tracks		47
How to determine		
Number and Depth of Cable Loops, Storage Distance, Cable Length, Number of Carriers		48
Graphs to find Number of Cable Loops considering 10, 15 and 20 % cable safety length		49 – 51

Catalog No. 8a: Cable Carriers on □ -Tracks

Catalog No. 8bF: Cable Carriers for flatform cable on I -Beams

Catalog No. 8bR: Cable Carriers for round cable on I -Beams

Catalog No. 8c: Cable Carriers on ◇ -Tracks

Catalog No. 8L: Conductor cables & Fittings



VAHLE FESTOON SYSTEMS

General

VAHLE Festoon Systems support conductor cables (flat or round) and hoses (hydraulic and pneumatic applications) for delivering power and control to mobile equipment in a safe, efficient and maintenance free method.

The cable carriers are well guided inside their □-tracks and protected against humidity, dust and icing.

All box-tracks can be bent in accordance to the system layout, considering the minimum bending radii and the permissible cable loops.

VAHLE cable carriers contained in this catalog comply with the VDE and most international regulations.

The use of flatform cable is highly recommended due to better bending properties compared to round cable. The minimum bending radius permissible for round cable is 5 times the cable diameter – for flat cable it is 5 times the thickness of the cable. This formula allows considerably smaller bend radii for flat cable, minimizing the required Festoon System storage distance which is normally within the length of equipment (e. g. hoist trolley – see page 4).

VAHLE cable carriers not only deliver power and control to mobile equipment which has reciprocal motion but also support large quantities of data cables including optic fibres travelling independently from the mobile machinery. The relevant control carriers with and without push button lifting are also shown in this catalog.

Layout

Selection of the proper carriers and components must be based on the choosen cable (see our catalog 8L – Conductor Cables and Fittings) or hose data that meets your electrical and mechanical requirements.

Refer to the pages 46 – 48 or send us the completed Questionnaire on page 4. Prints or sketches for system layouts including curves would be appreciated whenever obtainable.

For extra heavy duty or arduous applications it is recommended to check in our catalogs 8b F & R for our Innovative Festoon Technology on I-Beam tracks or 8c for Festoon Systems on diamond □ shaped tracks.

In any case we welcome your inquiries and guarantee our prompt quotations.

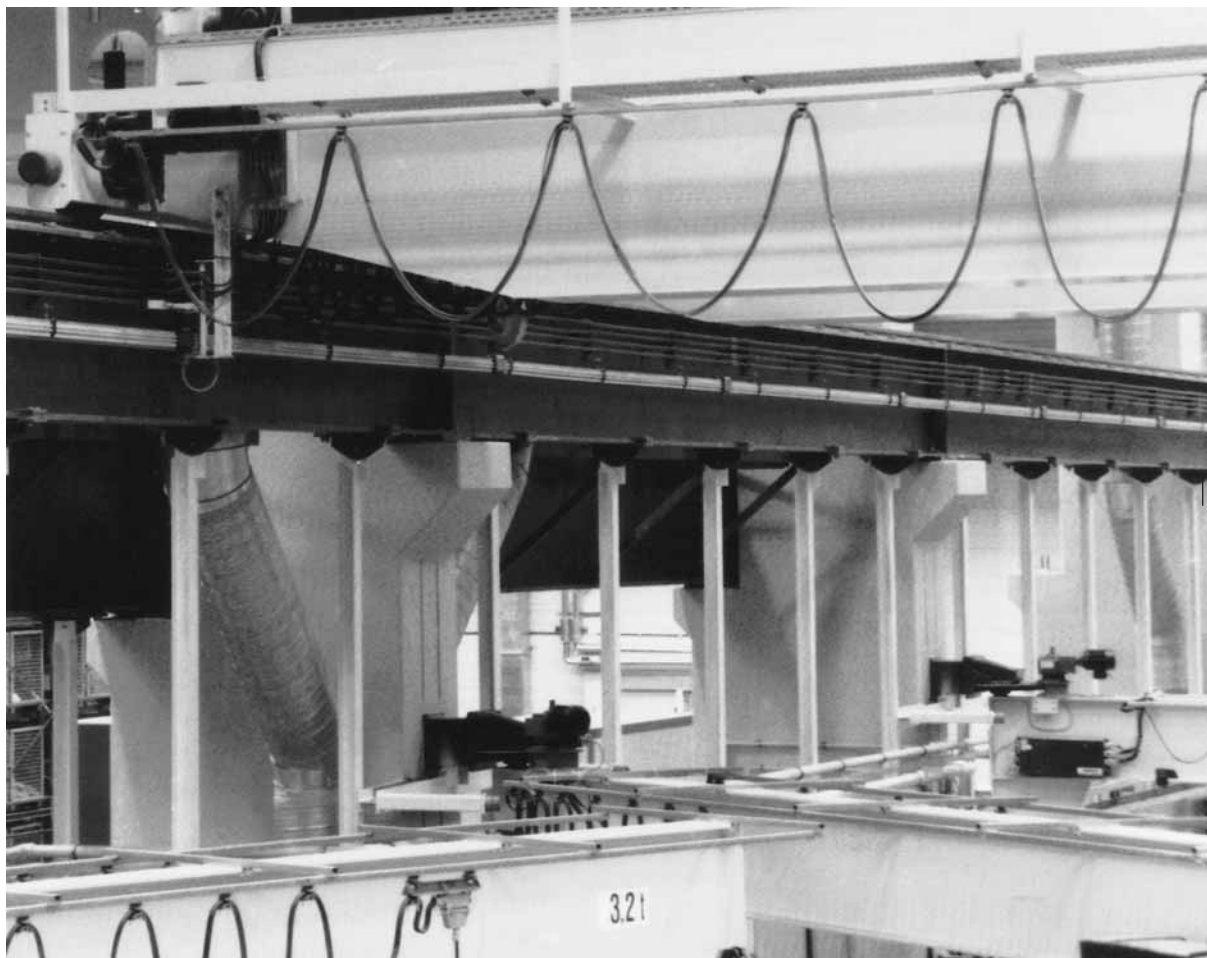



QUESTIONNAIRE

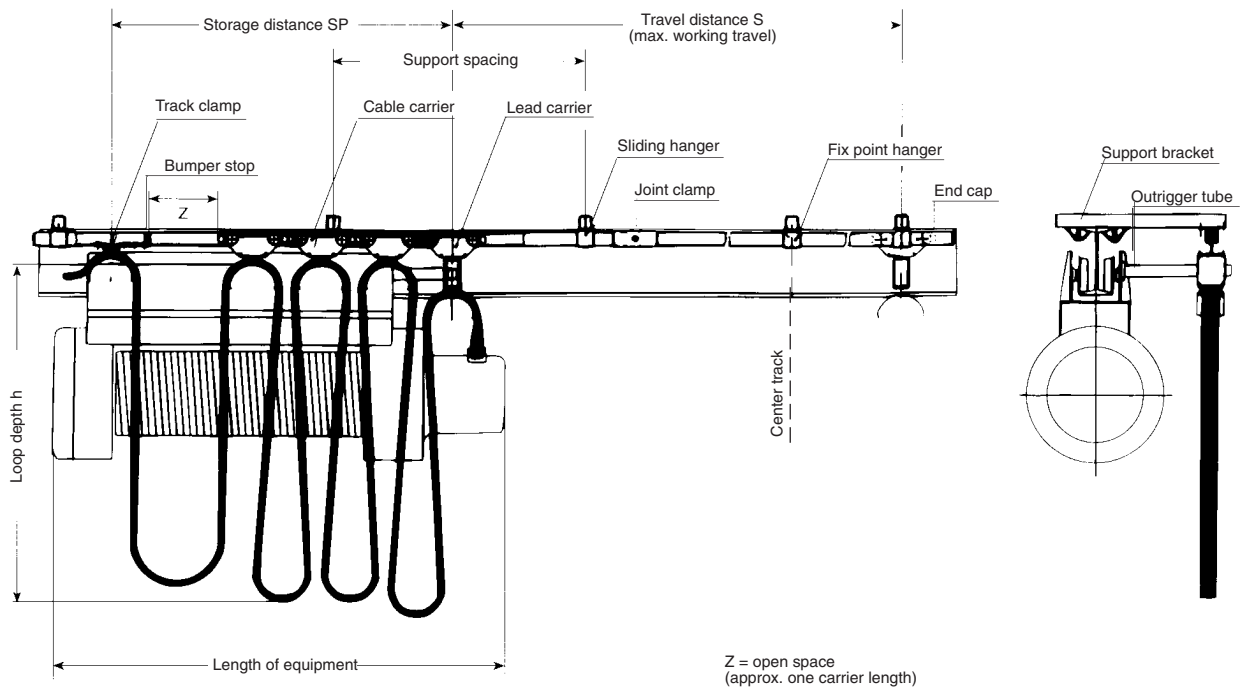

Name and Address of Customer: _____

Ref.: _____

1. Type of Application: _____

2. Outdoors Indoors _____

3. Temperature range _____

4. Is round or flatform cable envisaged? _____

5. How much space is available for storage? SP = _____ m

6. Is it possible to extend the track for the festoon cable system in case the length of equipment is insufficient for storage space?

Yes, by _____ m; no, not possible.

7. Special operating conditions: _____

8. Length of equipment: _____ m

9. Travel distance: S = _____ m

10. Travel speed: V = _____ m/min

11. Acceleration: a = _____ m/s²

12. Max loop depth: h = _____ m

13. Hookup cable length required at Track clamp side: LM = _____ m

14. Hookup cable length required at Lead carrier side: LM = _____ m

15. Required cables:

No. of cables	No. & Size of conductors	cable OD ø mm	width x thickness of flatform cables



S 1 TRACK AND ACCESSORIES

acid
proof

Stain-
less

Track

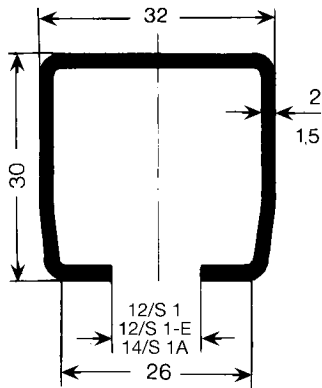

Type	S1	S1A	S1-E
Order-No. -in 6 m sections	312 946	312 966	312 956
Order-No. -in 4 m sections	312 944	312 964	312 954
Order-No. -surcharge for curves	310 470	310 470	312 472
for Carrier type	WS 1, WST 1		WST 1-E
Thickness	2 mm	1,5 mm	2 mm
Material	steel, galvanized		V 4 A, stainless steel
Supply lengths	6 m and 4 m		
Standard support spacing	As per Page 47, in straight system max. 2 m, in curves max. 1m.		
Moment of inertia Jx	2,42 cm ⁴	1,9 cm ⁴	2,42 cm ⁴
Section modulus Wx	1,45 cm ³	1,1 cm ³	1,45 cm ³
Weight	1,550 kg/m	1,190 kg/m	1,550 kg/m

The delivery of curves is possible. Please send us your inquiry.
Max. system length: 100 m

Hanger underhung

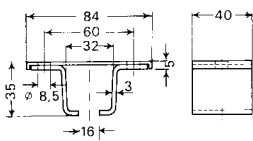

Type	Fixpoint hanger FAS 1
Order-No.	310 500
Material	steel, galvanized
Weight	0,160 kg

For up to 30 m runs only.

1 pair of bolts M 8 x 25, Order-No. 310 510 to be ordered separately for each hanger or provided by customer.

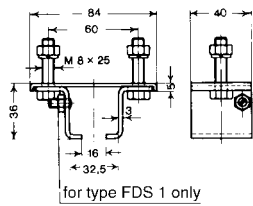

Type	Sliding hanger ADS 1 (1)	Fixpoint hanger FDS 1	Sliding hanger ADS 1-E (1)	Fixpoint hanger FDS 1-E
Order-No.	310 370	310 430	312 393	312 394
Material	steel, galvanized		V 4 A, stainless steel	
Weight	0,200 kg	0,210 kg	0,200 kg	0,210 kg

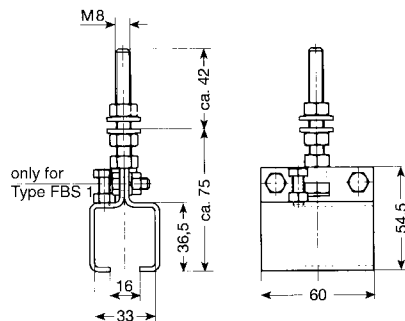

Type	Sliding hanger ABS 1 (1)	Fixpoint hanger FBS 1
Order-No.	312 863	312 864
Material	steel, galvanized	
Weight	0,226 kg	0,234 kg

Hanger underhung for HK support

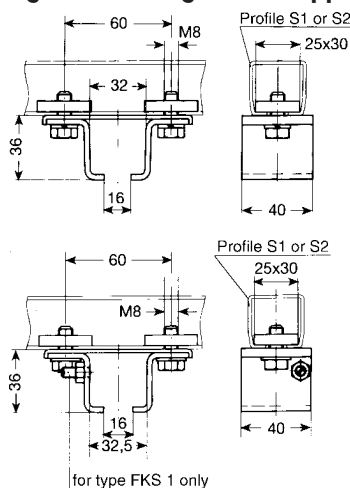

Type	Fixpoint hanger FAKS 1 (clamp)
Order-No.	310 590
Material	steel, galvanized
Weight	0,260 kg

For up to 30 m runs only.

Type	Sliding hanger AKS 1 (1)	Fixpoint hanger FKS 1	Sliding hanger AKS 1-E (1)	Fixpoint hanger FKS 1-E
Order-No.	310 380	310 450	312 457	312 458
Material	steel, galvanized		V 4 A, stainless steel	
Weight	0,260 kg	0,270 kg	0,260 kg	0,270 kg

(1) For systems with control-carriers use fixpoint hangers only.



S 1 ACCESSORIES

acid
proof

Stain-
less

Double Hanger for S 1 Track

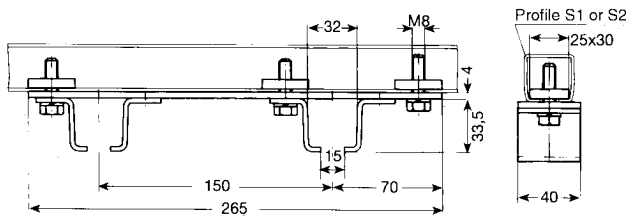

Type	DFAK-S 1 (clamp)
Order-No.	312 599
Material	steel, galvanized
Weight	0,660 kg

Hanger lateral

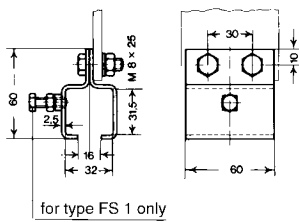

Type	Sliding hanger AS 1(1)	Fixpoint hanger FS 1
Order-No.	310 030	310 040
Material	steel, galvan.	steel, galvan.
Weight	0,220 kg	0,230 kg

Hanger lateral

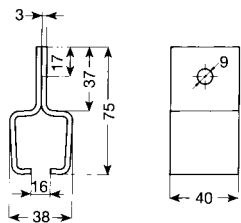

Type	Fixpoint hanger FO-S 1 (clamp)
Order-No.	312 809
Material	steel, galvanized
Weight	0,160 kg

For up to 30 m runs only.

Hanger for tube

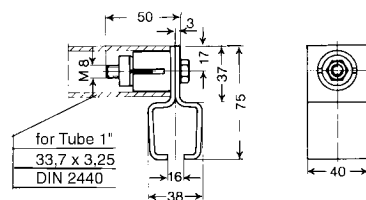

Type	Fixpoint hanger FR 1-S 1 (clamp)
Order-No.	310 991
Material	steel, dowel: polyamid
Weight	0,215 kg

Joint Clamp

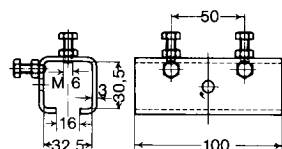

Type	VS 1	VS 1-E
Order-No.	310 050	312 392
Material	steel, galvanized	V 4 A, stainless steel
Weight	0,340 kg	0,340 kg

End Cap



Type		K 30
Order-No.		360 023
Material		polyethylene
Weight		0,008 kg



S 1 ACCESSORIES

acid
proof

Stain-
less

Bumper stop

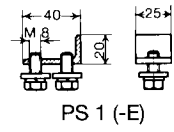

PS 1 (-E)

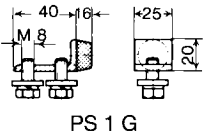

PS 1 G

Typ	PS 1	PS 1 G	PS 1-E
Order-No.	310 300	310 360	312 395
Material	steel, galvanized	steel, galvanized	V 4 A, stainless steel
Weight	0,080 kg	0,100 kg	0,080 kg

Bumper stop

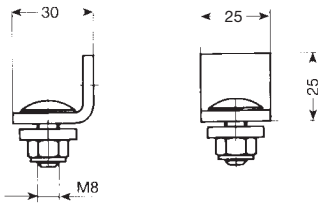

Typ	PS 1-1
Order-No.	312 605
Material	steel, galvanized
Weight	0,063 kg

Flat Nut w/bolt and washer

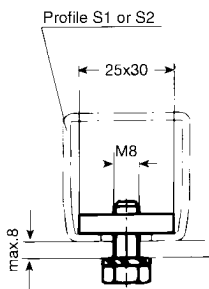

Typ	M 8 x 20	M 8 x 20 E
Order-No.	312 600	313 454
Material	steel, galvanized	V4A, stainless steel
Weight	0,044 kg	0,044 kg

Clamps for round cables and hoses

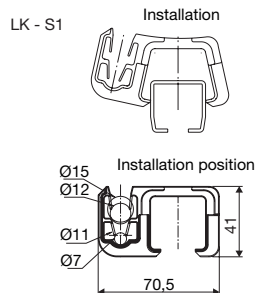
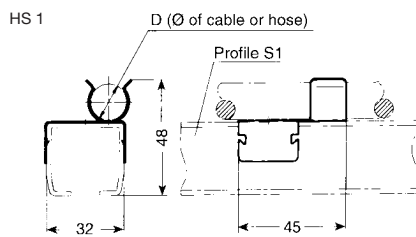

Type	Material	Weight kg	Dim. D mm	Order-No.
HS 1-D 9	stainless	0,010	8 - 10	312 667
HS 1-D 16	steel	0,011	15 - 20	312 666
LK-S1	PVC	0,010	7 - 15	313 379



S 1 ACCESSORIES

acid proof

Stainless

Standard Brackets

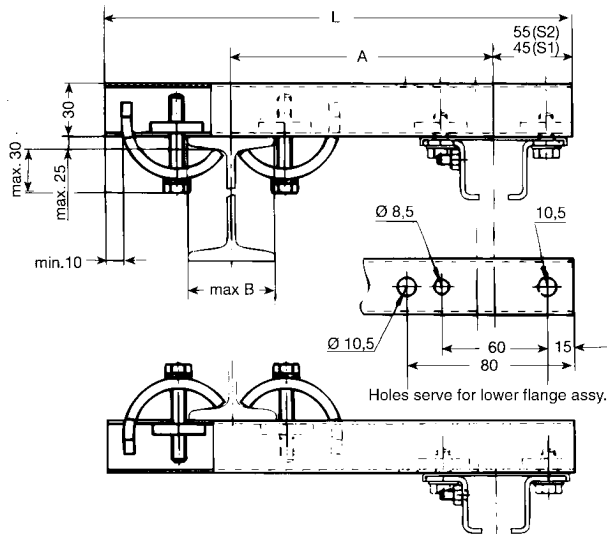

Choose dim. A per local requirements and make sure that hoist wheels have enough clearance.

Select next larger size bracket when your I-Beam dim. B is more than 210 mm and refer to page 9 for heavy duty brackets.

Type	Material	Weight kg	A (adjustable) mm	L mm	max. B mm	Order-No.	Type	Mat.	Order-No.
HK 200	steel galvanized	0,980	200	400	210 ⁽¹⁾	310 220	HK 200-E	stainl. steel V 4 A	312 510
HK 300		1,130	300	500	210 ⁽¹⁾	310 230	HK 300-E		312 511
HK 400		1,290	400	600	210 ⁽¹⁾	310 240	HK 400-E		312 512
HK 500		1,430	500	700	210 ⁽¹⁾	310 250	HK 500-E		312 513

Scope of supply: 1 pair of claws and rail short length S1.
Hangers AKS 1, FKS 1 and FAKS 1 to be ordered separately.

Bracket Bars for HK

Type	Material	Weight kg	L mm	Order-No.	Type	Mat.	Order-No.
S 1-400	steel galvanized	0,620	400	310 600	S 1E-400	stainl. steel V 4 A	312 515
S 1-500		0,780	500	310 610	S 1E-500		312 516
S 1-600		0,930	600	310 620	S 1E-600		312 517
S 1-700		1,090	700	310 630	S 1E-700		312 518

Claws for HK

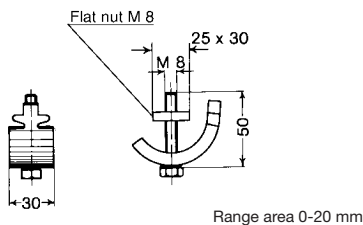

Type	SP	SP-E
Order-No.	310 390	312 514
Material	steel, galvanized	V 4 A, stainless steel
Weight	0,200 kg	0,200 kg

Flat nut M 8 separately available.
Order-No. 310 955

Flat nut M 8-E stainless steel separately available.
Order-No. 312 545

Support Attachment for HK

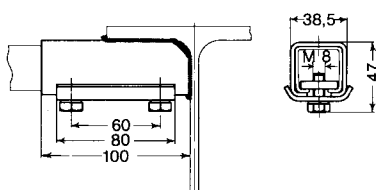

Type	AH 1
Order-No.	310 400
Material	steel, galvanized
Weight	0,460 kg

Bracket bar and hangers to be ordered separately.



S 1 ACCESSORIES

acid proof

Stain-less

General Assembly of Heavy Duty Bracket

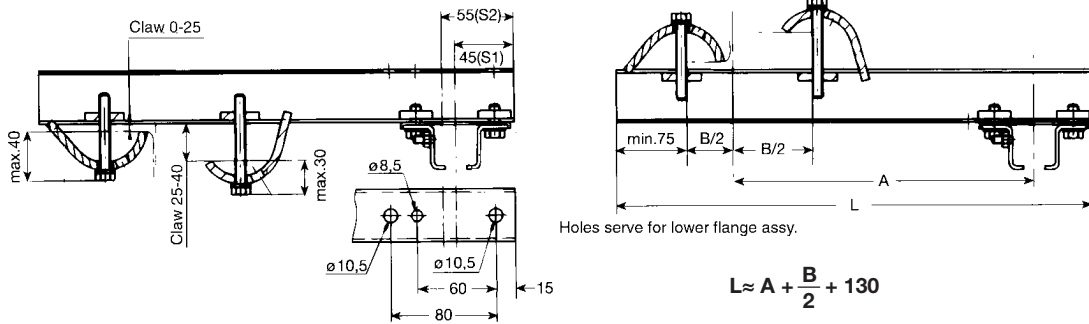

Dimension A is based on the width of the current consumer (e.g. the trolley). Please consider the running wheel diameter (flange) of the chassis in overhead monorails.

Bracket Bars for HK heavy duty

The track sections are provided with borings to fix the support hangers at the bottom flange of the track profile.

Type	Material	Weight kg	Dim. L mm	Order-No.	Type	Mat.-	Order-No.
S 2- 400	steel galvanized	0,996	400	315 402	S 2E- 400	stainl. steel V 4 A	316 513
S 2- 500		1,245	500	315 403	S 2E- 500		316 514
S 2- 600		1,494	600	315 404	S 2E- 600		316 515
S 2- 700		1,743	700	315 405	S 2E- 700		316 516
S 2- 800		1,992	800	315 406	S 2E- 800		316 517
S 2- 900		2,241	900	315 407	S 2E- 900		316 518
S 2-1000		2,490	1000	315 408	S 2E-1000		316 519
S 2-1100		2,739	1100	315 409	S 2E-1100		316 520
S 2-1200		2,988	1200	315 410	S 2E-1200		316 521

Claws for HK heavy duty

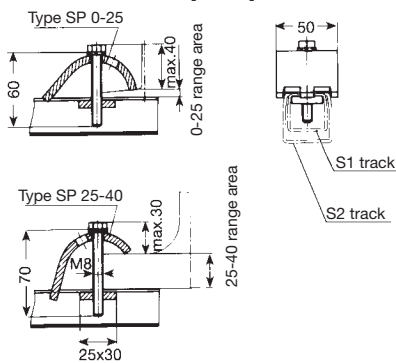

Type	SP 0-25	SP 0-25-E
Order-No.	312 643	316 690
Material	steel, galvanized	V 4 A, (stainless steel)
Weight	0,286 kg	0,286 kg

Type	SP 25-40	SP 25-40-E
Order-No.	312 644	316 695
Material	steel, galvanized	V 4 A, (stainless steel)
Weight	0,287 kg	0,287 kg

Support Attachment for HK heavy duty

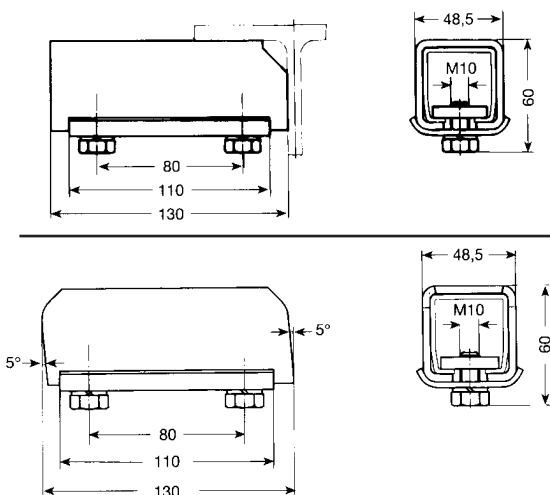

Type	AH 2
Order-No.	310 989
Material	Stahl
Weight	0,940 kg

Typ	AH 2-2
Order-No.	312 648
Material	Stahl
Weight	0,854 kg



S 1 CABLE CARRIERS AND ACCESSORIES

- Polyamid type -

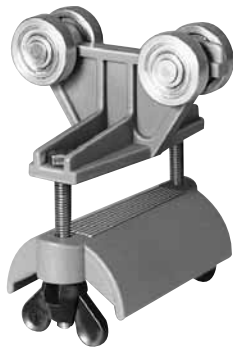

Engineering Data

Type	WS 1 F (not suitable for curved track)
Wheels	<p>A) Polyamid rollers on bushed bearing; axle galvanized Material: polyamid, Travelling speed: ca. 50 m/min.</p> <p>B) Polyamid rollers on stainless bushed bearing Material: polyamid, Travelling speed: ca. 50 m/min.</p> <p>C) Polyamid rollers with ball bearing; inner race hardened, galvanized outer race Polyamid, Travelling speed: ca. 60 m/min.</p> <p>D) hardened and galvanized steel rollers with precision ball bearing, sealed against dust and splash water.</p> <p>Temperature resistance: lub. grease of wheels: -30° C to +125° C Travelling speed: ca. 80 m/min.</p>
Material	<p>Carrier body: Polyamid Support saddle: Polyamid Hardware: galvanized Temperature resistance: -30° C to +100° C</p>
Max. cable load	<p>max. 8 kg per Carrier with roller A max. 10 kg per Carrier with roller B + C max. 16 kg per Carrier with roller D</p>
for corrosive sites	use system S 1-E or K1

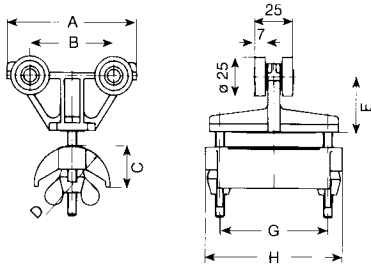

Cable Carriers for flatlarm cables

Type	wheels	max. thickness of individual cable mm	max. clamping capacity mm height x width	mm								Weight kg	Order No. (1)	with patented nut Order-No. (2)
				A	B	C	D	E	G	H				
WS 1 F/ 85 G	A	8	17 x 65	85	55	25	50	37	71	90	0,120	310 958	312 686	
WS 1 F/ 85 K	B										0,130	310 180	312 687	
WS 1 F/ 85 KL	C										0,130	310 320	312 688	
WS 1 F/ 85	D										0,190	310 070	312 689	
WS 1 F/125-50 G	A	8	37 x 65	125	95	40	50	37	71	90	0,150	312 759	312 760	
WS 1 F/125-50 K	B										0,160	312 761	312 762	
WS 1 F/125-50 KL	C										0,160	312 763	312 764	
WS 1 F/125-50	D										0,220	312 765	312 766	
WS 1 F/125-80 G	A	10	22 x 65	125	95	40	80	37	71	90	0,170	312 767	312 768	
WS 1 F/125-80 K	B										0,180	312 769	312 770	
WS 1 F/125-80 KL	C										0,180	312 771	312 772	
WS 1 F/125-80	D										0,240	312 773	312 774	

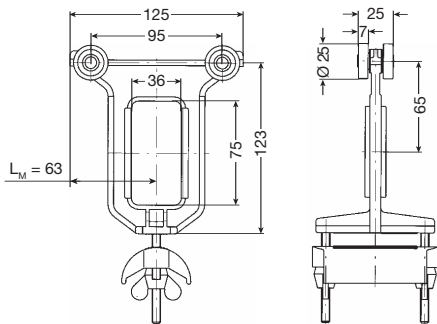

Lead Carriers for flatlarm cables

Type	wheels	for Carrier type	Weight kg	Order No. (1)	with patented nut Order-No. (2)
MS 1 F/125-50 G	A	WS 1 F/ 85 G, WS 1 F/125-50 G	0,140	313 281	313 285
MS 1 F/125-50 K	B	WS 1 F/ 85 (K, G), WS 1 F/125-50 (K, G)	0,144	313 280	313 284
MS 1 F/125-50 KL	C	WS 1 F/ 85 (KL, K, G), WS 1 F/125-50 (KL,K,G)	0,158	313 279	313 283
MS 1 F/125-50	D	WS 1 F/85 (all types) WS 1 F/125-50 (all types)	0,200	313 278	313 282
MS 1 F/125-80 G	A	WS 1 F/125-80 G	0,156	313 293	313 297
MS 1 F/125-80 K	B	WS 1 F/125-80 (K, G)	0,162	313 292	313 296
MS 1 F/125-80 KL	C	WS 1 F/125-80 (KL, K, G)	0,174	313 291	313 295
MS 1 F/125-80	D	WS 1 F/125-80 (all types)	0,216	313 290	313 294

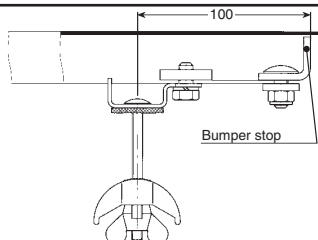

Track Clamps for flatlarm cables

Type	for Carrier type	Weight kg	Order No. (1)	with patented nut Type	Order-No.
ES 1 F/ 85	WS 1 F/ 85 (all types) WS 1 F/125-50 (all types)	0,220	313 303	EST 1-2 F/ 85-PM	313 304
ES 1 F/125-80	WS 1 F/125-80 (all types)	0,240	313 307	EST 1-2 F/125-PM	313 308

Bumper stop PS 1, PS 1-1, PS 1 G to be ordered separately.

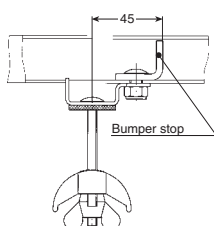

Track Clamp with bumper for flatlarm cables

Type	for Carrier type	Weight kg	Order-No. (1)	with patented nut Type	Order-No.
EP S1 F/ 85	WS 1 F/ 85 (all types)	0,230	313 305	EPST 1-2 F/85-PM	313 306

(1) hex. nut type

(2) with patented quick-set nut use suffix PM, e.g. WS 1 F/85-PM for Order-No. 312 689



S 1 CABLE CARRIERS AND ACCESSORIES

- Polyamid swivel type -

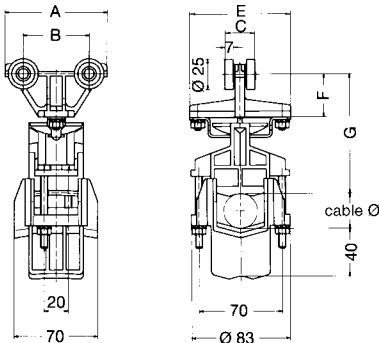

Engineering Data

Type	WS 1 R (not suitable for curved track)
Wheels	A) Polyamid rollers on bushed bearing; axle galvanized Material: polyamid, Travelling speed: ca. 50 m/min. B) Polyamid rollers on stainless bushed bearing Material: polyamid, Travelling speed: ca. 50 m/min.n. C) Polyamid rollers with ball bearing; inner race hardened, galvanized outer race Polyamid, Travelling speed: ca. 60 m/min. D) hardened and galvanized steel rollers with precision ball bearing, sealed against dust and splash water Temperature resistance: lub. grease of wheels: -30° C to +125° C Travelling speed: ca. 80 m/min.
Material	Carrier body: Polyamid Support saddle: Polyamid Hardware: galvanized Temperature resistance: - 30° C to +100° C
Max. cable load	max. 8 kg per Carrier with roller A max. 10 kg per Carrier with roller B + C max. 16 kg per Carrier with roller D
for corrosive sites	use system S 1-E or K1

Cable Carriers for round cables and hoses

Type	Cable Ø	Wheels	A	B	C	D	E	F	G	Weight kg	Order- No.
			mm								
WS 1 R/85 G	5 mm to 38 mm	A								0,260	313 332
WS 1 R/85 K		B								0,270	312 486
WS 1 R/85 KL		C	85	55	25	25	85	36	99	0,280	312 487
WS 1 R/85		D								0,320	312 485

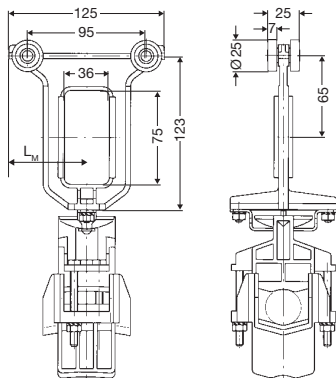

Lead Carriers for round cables and hoses

Type	for Carrier type	Lm	Weight kg	Order- No.
MS 1 R/125 G	WS 1 R/85 G	63	0,284	313 289
MS 1 R/125 K	WS 1 R/85 (K, G)	63	0,288	313 288
MS 1 R/125 KL	WS 1 R/85 (KL, K, G)	63	0,302	313 287
MS 1 R/125	WS 1 R/85 (all types)	63	0,304	313 286

Track Clamp for round cables and hoses

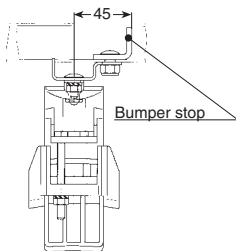

Type	for Carrier type	Weight kg	Order- No.
EPST 1-2 R	WS 1 R (all types)	0,346	313 322

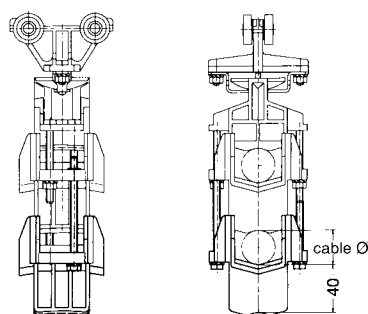

Support Saddle for round cables and hoses for additional tiers

Type	for Carrier type	Weight kg	Order- No.
LAR	WS 1 R (all types)	0,110	312 500



S 1 CABLE CARRIERS - Steel type -



acid
proof

Stain-
less



Support saddle
with hex. nut



Support saddle
with patented nut

Engineering Data

Type	WST 1 F	WST 1 F-E	WST 1 F K-E
Wheels	ball bearings sealed against dust and splash water hardened, galvanized Temperature resistance Lub. grease of wheels: -30° C to +125° C Travelling speed: ca. 80 m/min.	sealed ball bearings stainless steel, V 4 A -30° C to +150° C ca. 80 m/min.	Polyamid rollers on bushed bearing ca. 50 m/min.
Material	Carrier body: steel, galvanized Support saddle: steel, galvanized D = 140 - aluminium Bumper: Neoprene Hardware: galvanized Temperature resistance: - 30° C to +100° C	with patented nut Support saddle Polyamid	V 4 A, stainless steel V 4 A, stainless steel Neoprene V 4 A, stainless steel - 30° C to + 80° C
Max. cable load	max. 22 kg per carrier	max. 12 kg per carrier	max. 8 kg per carrier
Depth of cable loop	in curves max. 0,3 x track radius, consider tension relief		not in curves
for corrosive sites	use system S 1-E or K 1		

Cable Carriers for flatform cables

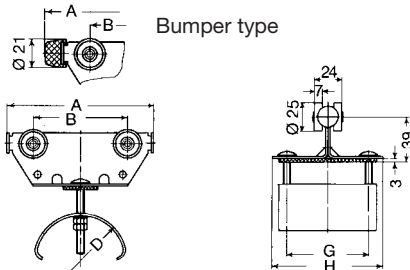

Type	max. thicken. of individual cable mm	max. clamping capacity in mm height x width	A	B	Ø D	G	H	Weight kg	Order-No.	with patented nut Order-No ⁽²⁾	Type	Order-No.	Type	Order-No.
			mm											
WST 1 F/ 85 ⁽¹⁾	8	17 x 65	85	43	50	85	85	0,360	312 000	312 789	WST 1 F/ 85 E ⁽¹⁾	312 381	WST 1 F/ 85 K-E ⁽¹⁾	313 218
WST 1 F/ 85 P		29 x 65	110					0,370	312 010	312 790	WST 1 F/ 85P-E	312 387	WST 1 F/ 85 KP-E	313 219
WST 1 F/125-50 ⁽¹⁾		37 x 65	125					0,460	312 533	312 791	WST 1 F/125-50-E ⁽¹⁾	312 519	WST 1 F/125-50K-E ⁽¹⁾	313 221
WST 1 F/125-50 P	10	50 x 65	150	80	80	97	97	0,470	312 534	312 792	WST 1 F/125-50P-E	312 520	WST 1 F/125-50KP-E	313 222
WST 1 F/125 ⁽¹⁾		22 x 65	125					0,520	312 020	312 793	WST 1 F/125-E ⁽¹⁾	312 384	WST 1 F/125 K-E ⁽¹⁾	313 223
WST 1 F/125 P		34 x 65	150					0,530	312 030	312 794	WST 1 F/125P-E	312 388	WST 1 F/125 KP-E	313 224
WST 1 F/150-50 ⁽¹⁾	8	50 x 65	150	105	80	71	85	0,480	312 537	312 795	WST 1 F/150-50-E ⁽¹⁾	312 560	WST 1 F/150-50 K-E ⁽¹⁾	313 225
WST 1 F/150-50 P		62 x 65	175					0,490	312 538	312 796	WST 1 F/150-50P-E	312 561	WST 1 F/150-50 KP-E	313 226
WST 1 F/150-80 ⁽¹⁾		35 x 65	150					0,540	312 539	312 797	WST 1 F/150-80-E ⁽¹⁾	312 562	WST 1 F/150-80 K-E ⁽¹⁾	313 227
WST 1 F/150-80 P	10	47 x 65	175	100	85	85	85	0,550	312 540	312 798	WST 1 F/150-80P-E	312 563	WST 1 F/150-80 KP-E	313 228
WST 1 F/150 ⁽¹⁾		25 x 65	150					0,580	312 040		WST 1 F/150-E ⁽¹⁾	312 564	WST 1 F/150 K-E	313 229
WST 1 F/150 P		37 x 65	175					0,590	312 050		WST 1 F/150P-E	312 565	WST 1 F/150 KP-E	313 230
WST 1 F/200-100 ⁽¹⁾	12	50 x 65	200	155	100	85	85	0,680	312 831					
WST 1 F/200-100 P		62 x 65	225					0,700	312 832					
WST 1 F/200-140 ⁽¹⁾		30 x 65	200					0,670	312 833					
WST 1 F/200-140 P	14	42 x 65	225	205	140	85	85	0,680	312 834					
WST 1 F/250-140 ⁽¹⁾		55 x 65	250					0,740	312 835					
WST 1 F/250-140 P		67 x 65	275					0,750	312 836					

⁽¹⁾ without Bumper

⁽²⁾ with patented quick-set nut use suffix PM, e.g. WST 1 F/85 PM for Order-No. 312 789



S 1 LEAD CARRIERS AND TRACK CLAMPS – Steel type –



acid
proof

Stain-
less

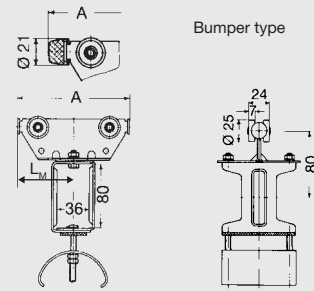

Lead Carriers for flatrom cables

Type	for Carrier type	LM	A mm	Weight kg	Order-No.	with patented nut Order-No. ⁽²⁾	Type	Order-No.	Type	Order-No.
MST 1 F/ 85 ⁽¹⁾	WST 1 F/ 85	43	85	0,730	312 080	312 799	MST 1 F/ 85-E ⁽¹⁾	312 382	MST 1 F/ 85 K-E ⁽¹⁾	313 231
MST 1 F/ 85 P	WST 1 F/ 85 P	55	110	0,740	312 090	312 800	MST 1 F/ 85 P-E	312 389	MST 1 F/ 85 KP-E	313 232
MST 1 F/125-50 ⁽¹⁾	WST 1 F/125-50	63	125	0,830	312 535	312 801	MST 1 F/125-50-E ⁽¹⁾	312 521	MST 1 F/125-50 K-E ⁽¹⁾	313 233
MST 1 F/125-50 P	WST 1 F/125-50 P	75	150	0,840	312 536	312 802	MST 1 F/125-50 P-E	312 522	MST 1 F/125-50 KP-E	313 234
MST 1 F/125 ⁽¹⁾	WST 1 F/125	63	125	0,880	312 100	312 803	MST 1 F/125-E ⁽¹⁾	312 385	MST 1 F/125 K-E ⁽¹⁾	313 235
MST 1 F/125 P	WST 1 F/125 P	75	150	0,890	312 110	312 804	MST 1 F/125 P-E	312 390	MST 1 F/125 KP-E	313 236
MST 1 F/150-50 ⁽¹⁾	WST 1 F/150-50	75	150	0,850	312 541	312 805	MST 1 F/150-50-E ⁽¹⁾	312 566	MST 1 F/150-50 K-E ⁽¹⁾	313 237
MST 1 F/150-50 P	WST 1 F/150-50 P	88	175	0,860	312 542	312 806	MST 1 F/150-50 P-E	312 567	MST 1 F/150-50 KP-E	313 238
MST 1 F/150-80 ⁽¹⁾	WST 1 F/150-80	75	150	0,900	312 543	312 807	MST 1 F/150-80-E ⁽¹⁾	312 568	MST 1 F/150-80 K-E ⁽¹⁾	313 239
MST 1 F/150-80 P	WST 1 F/150-80 P	88	175	0,910	312 544	312 808	MST 1 F/150-80 P-E	312 569	MST 1 F/150-80 KP-E	313 240
MST 1 F/150 ⁽¹⁾	WST 1 F/150	75	150	0,950	312 120		MST 1 F/150-E ⁽¹⁾	312 570	MST 1 F/150 K-E ⁽¹⁾	313 241
MST 1 F/150 P	WST 1 F/150 P	88	175	0,960	312 130		MST 1 F/150 P-E	312 571	MST 1 F/150 KP-E	313 242
MST 1 F/200-100 ⁽¹⁾	WST 1 F/200-100	100	200	1,050	312 837					
MST 1 F/200-100 P	WST 1 F/200-100 P	113	225	1,070	312 838					
MST 1 F/200-140 ⁽¹⁾	WST 1 F/200-140	100	200	1,030	312 839					
MST 1 F/200-140 P	WST 1 F/200-140 P	113	225	1,040	312 840					
MST 1 F/250-140 ⁽¹⁾	WST 1 F/250-140	125	250	1,110	312 841					
MST 1 F/250-140 P	WST 1 F/250-140 P	138	275	1,120	312 842					

Track Clamps for flatrom cables

Type	for Carrier type	LE mm	Weight kg	Order-No.	with patented nut Order-No. ⁽²⁾	Type	Order-No.
EST 1-2 F/ 85	WST 1 F/ 85 (P)	140	0,290	313 315	313 304	EST 1-2 F/ 85-E	312 383
	WST 1 F/125-50 (P)						
	WST 1 F/150-50 (P)						
EST 1-2 F/125	WST 1 F/125 (P)	140	0,370	313 316	313 308	EST 1-2 F/125-E	312 386
	WST 1 F/150-80 (P)						
EST 1-2 F/150	WST 1 F/150 (P)	140	0,410	313 317		EST 1-2 F/150-E	312 572
EST 1-2 F/100-2	WST 1 F/200-100 (P)	140	0,410	313 318			
EST 1-2 F/140-2	WST 1 F/200-140 (P)	165	0,430	313 319			
	WST 1 F/250-140 (P)						

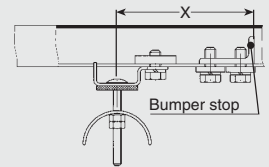

Bumper stop PS 1, PS 1-1, PS 1 G or PS 1-E to be ordered separately.

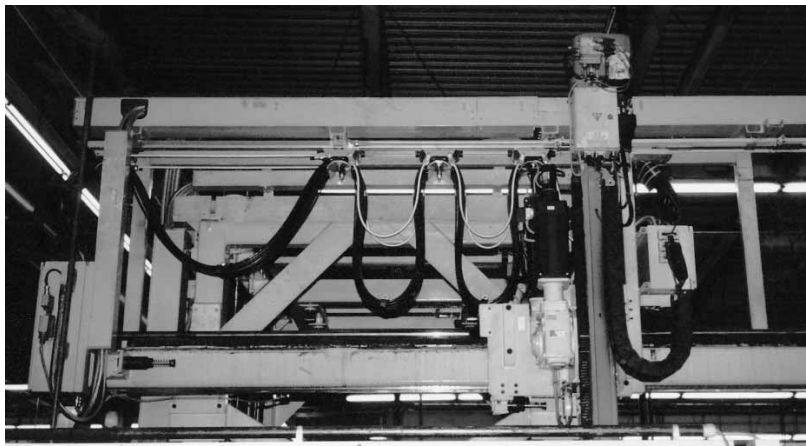

VAHLE Festoon feeding robotic production.

⁽¹⁾ without Bumper

⁽²⁾ with patented quick-set nut use suffix PM



LS 1 CABLE CARRIERS AND ACCESSORIES – Steel type –



Engineering Data

Type	WST 1 F
Wheels	ball bearings sealed against dust and splash water hardened, galvanized Temperature resistance Lub. grease of wheels: -30° C to +125° C Travelling speed: ca. 80 m/min.
Materialf	Carrier body: steel, galvanized Support saddle: steel, galvanized; D = 100 & 140 aluminium Bumper: Neoprene Hardware: galvanized Temperature resistance: - 30° C to +100° C
Max. cable load	max. 22 kg per carrier
Depth of cable loop	in curves max. 0,3 x track radius, consider tension relief
for corrosive sites	use system S 1-E or K 1

Cable Carriers for flatform cables

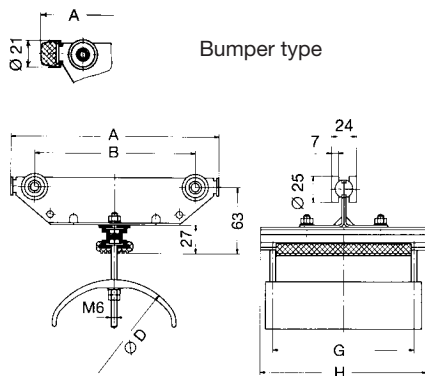

Type	max. thicken. of individual cable mm	max. clamping capacity in mm height x width	mm				Weight kg	Order-No.	
			A	B	Ø D	H			
WST 1 F/125-50 B ⁽¹⁾	8	37 x 100	125	80	50	110	134	0,630	312 902
WST 1 F/125-50 B P		50 x 100	150					0,640	312 903
WST 1 F/125-80 B ⁽¹⁾	10	22 x 100	125	80	80	110	134	0,720	312 904
WST 1 F/125-80 B P		34 x 100	150					0,730	312 905
WST 1 F/150-100 B 160 ⁽¹⁾	12	25 x 130	150	105	100	136	160	0,750	312 845
WST 1 F/150-100 B 160 P		37 x 130	175					0,760	312 846
WST 1 F/200-100 B 160 ⁽¹⁾	12	50 x 130	200	155	100	136	160	0,840	312 847
WST 1 F/200-100 B 160 P		62 x 130	225					0,850	312 848
WST 1 F/200-140 B 160 ⁽¹⁾	14	30 x 130	200	205	140	136	160	0,970	312 849
WST 1 F/200-140 B 160 P		42 x 130	225					0,980	312 850
WST 1 F/250-140 B 160 ⁽¹⁾		55 x 130	250					1,040	312 851
WST 1 F/250-140 B 160 P		67 x 130	275					1,050	312 852

Lead Carriers for flatform cables

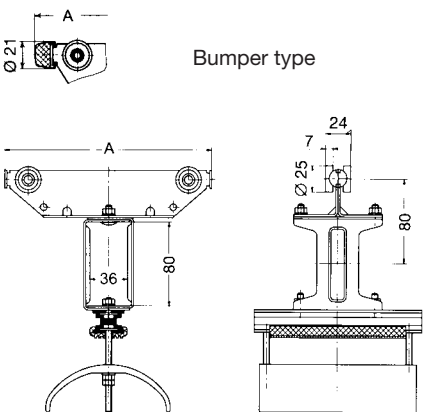

Type	for Carrier type	A mm	Weight kg	Order-No.
MST 1 F/125-50 B ⁽¹⁾	WST 1 F/125-50 B	125	1,000	312 906
MST 1 F/125-50 B P	WST 1 F/125-50 B P	150	1,010	312 907
MST 1 F/125-80 B ⁽¹⁾	WST 1 F/125-80 B	125	1,080	312 908
MST 1 F/125-80 B P	WST 1 F/125-80 B P	150	1,090	312 909
MST 1 F/150-100 B 160 ⁽¹⁾	WST 1 F/150-100 B 160	150	1,100	312 853
MST 1 F/150-100 B 160 P	WST 1 F/150-100 B 160 P	175	1,110	312 854
MST 1 F/200-100 B 160 ⁽¹⁾	WST 1 F/200-100 B 160	200	1,190	312 855
MST 1 F/200-100 B 160 P	WST 1 F/200-100 B 160 P	225	1,200	312 856
MST 1 F/200-140 B 160 ⁽¹⁾	WST 1 F/200-140 B 160	200	1,330	312 857
MST 1 F/200-140 B 160 P	WST 1 F/200-140 B 160 P	225	1,340	312 858
MST 1 F/250-140 B 160 ⁽¹⁾	WST 1 F/250-140 B 160	250	1,390	312 859
MST 1 F/250-140 B 160 P	WST 1 F/250-140 B 160 P	275	1,400	312 860

Track Clamps for flatform cables

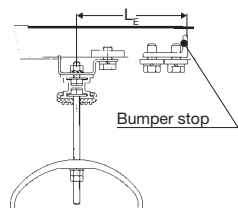

Bumper stop PS 1, PS 1-1, PS 1 G to be ordered separately.

Type	for Carrier type	L _E mm	Weight kg	Order-No.
EST 1-2 F/125-50 B	WST 1 F/125-50 B (P)	140	0,470	313 313
EST 1-2 F/125-80 B	WST 1 F/125-80 B (P)		0,520	313 314
EST 1-2 F/100 B 160	WST 1 F/150-100 B 160 (P)	140	0,560	313 311
	WST 1 F/200-100 B 160 (P)	155		
EST 1-2 F/140 B 160	WST 1 F/250-140 B 160 (P)	180		



S 1 CABLE CARRIERS AND ACCESSORIES – Steel type –



acid proof

Stainless



Engineering Data

Type	WST 1 R	WST 1 R-E	WST 1 RK-E
Wheels	ball bearings sealed against dust and splash water hardened, galvanized Temperature resistance: Lub. grease of wheels: -30° C to +125° C Travelling speed: ca. 80 m/min.	sealed ball bearing stainless steel, V 4 A -30° C to +150° C ca. 80 m/min.	Polyamid rollers on bushed bearing ca. 50 m/min.
Material	Carrier body: steel, galvanized Support saddle: Polyamid Bumper: Neoprene Hardware: galvanized Temperature resistance: -30° C to +100° C	V 4 A, stainless steel Polypropylene Neoprene V 4 A, stainless steel -10° C to +80° C	
Max. cable load	max. 22 kg per carrier	max. 12 kg per carrier	max. 8 kg per carrier
Depth of cable loop	in curves max. 0,3 x track radius; consider tension relief		not in curves
for corrosive sites	use system S 1-E or K 1		

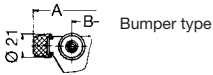

Bumper type

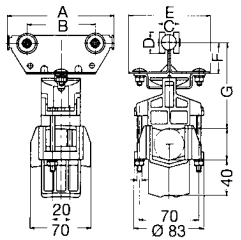

Cable Carriers for round cables and hoses

Type	Cable-Ø	A	B	C	D	E	F	G	Weight kg	Order-No.	Type	Order-No.	Type	Order-No.
WST 1 R/ 85 ⁽¹⁾	5 mm to 38 mm	85							0,430	312 491	WST 1 R/ 85-E ⁽¹⁾	312 523	WST 1 R/ 85 K-E	313 243
WST 1 R/ 85 P		110	43	24	25	85	36	99	0,460	312 492	WST 1 R/ 85 P-E	312 524	WST 1 R/ 85 KP-E	313 244
WST 1 R/125 ⁽¹⁾		125							0,540	312 493	WST 1 R/125-E ⁽¹⁾	312 525	WST 1 R/125 K-E	313 245
WST 1 R/125 P		150	80	24	25	97	36	99	0,570	312 494	WST 1 R/125 P-E	312 526	WST 1 R/125 KP-E	313 246

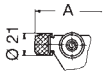

Lead Carriers for round cables and hoses

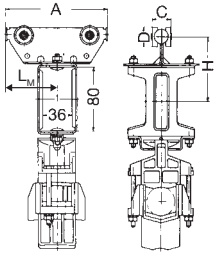

Type	for Carrier type	L _M	A	C	D	H	Weight kg	Order-No.	Type	Order-No.	Type	Order-No.
MST 1 R/ 85 ⁽¹⁾	WST 1 R/ 85	43	85	24	25	80	0,780	312 495	MST 1 R/ 85-E ⁽¹⁾	312 527	MST 1 R/ 85 K-E	313 247
MST 1 R/ 85 P	WST 1 R/ 85 P	55	110				0,810	312 496	MST 1 R/ 85 P-E	312 528	MST 1 R/ 85 KP-E	313 248
MST 1 R/125 ⁽¹⁾	WST 1 R/125	63	125				0,890	312 497	MST 1 R/125-E ⁽¹⁾	312 529	MST 1 R/125 K-E	313 249
MST 1 R/125 P	WST 1 R/125 P	75	150				0,920	312 498	MST 1 R/125 P-E	312 530	MST 1 R/125 KP-E	313 250

Track Clamp for round cables and hoses

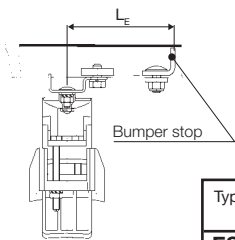

Type	for Carrier type	L _E mm	Weight kg	Order-No.	Type	Order-No.
EST 1-2 R	WST 1 R (all types)	100	0,340	313 321	EST 1 R-E	312 531

Bumper stop PS 1, PS 1-1, PS 1 G, PS 1-E to be ordered separately.

Support Saddle for round cables and hoses for additional tiers

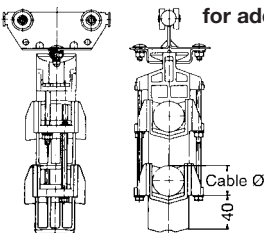

Type	for Carrier type	Weight kg	Order-No.	Type	Order-No.
LAR	WST 1 R (alle Typen)	0,110	312 500	LAR-E	312 532

⁽¹⁾ without Bumper



S 1 CABLE CARRIERS AND ACCESSORIES

- Steel type -



Engineering Data

Type	WST 1 R/250, WST 1 R/250 P
Wheels	ball bearings sealed against dust and splash water hardened, galvanized Temperature resistance Lub. grease of wheels: -30° C to +125° C Travelling speed: ca. 80 m/min.
Material	Carrier body: steel, galvanized Cable-loop: Polyamid Support saddle: Polyamid Hardware: galvanized Temperature resistance: - 30° C to +100° C
Max. cable load	max. 22 kg per carrier WST 1 R/250 (P)
for corrosive sites	use system S 1-E or K 1

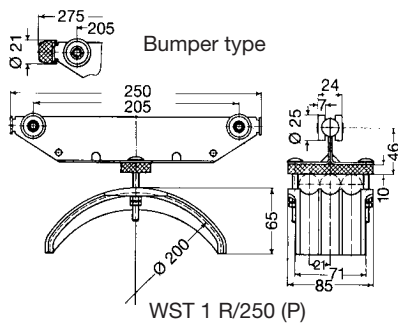

Cable Carriers for round cables and hoses

Type	max. cable-Ø mm	Weight kg	Order-No.
WST 1 R/250 ⁽¹⁾	3 x Ø 20	0,660	312 060
WST 1 R/250 P		0,690	312 070

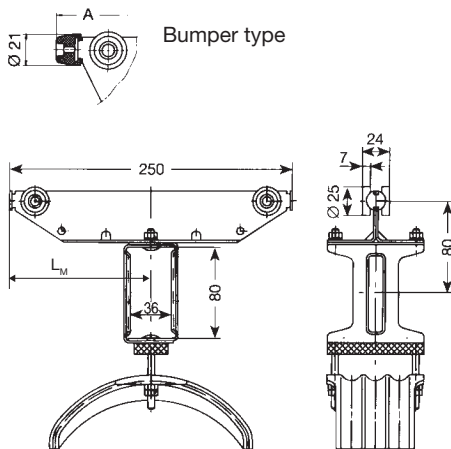

Lead Carriers for round cables and hoses

Support saddle same as for cable carriers

Type	for Carrier type	L _M	A mm	Weight kg	Order-No.
MST 1 R/250 ⁽¹⁾	WST 1 R/250	125	250	1,000	312 140
MST 1 R/250 P	WST 1 R/250 P	125	275	1,030	312 150

Track Clamp for round cables and hoses

Support saddle same as for cable carriers

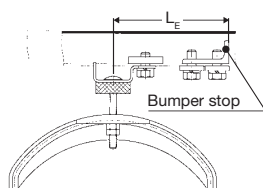

Bumper stop PS 1, PS 1-1, PS 1 G to be ordered separately.

Type	for Carrier type	L _E mm	Weight kg	Order-No.
ES 1 R/250	WST 1 R/250	165	0,298	313 320
	WST 1 R/250 P	178		



S 1 CABLE CARRIERS AND ACCESSORIES

- Steel type -



Engineering Data

Type	WR 1-Sch, WST 1-Sch
Wheels	ball bearings sealed against dust and splash water hardened, galvanized Temperature resistance Lub. grease of wheels: -30° C to +125° C Travelling speed: ca. 80 m/min.
Material	Carrier body: steel, galvanized S-Hook: steel, galvanized Cable-loop: Polyamid Hardware: galvanized Temperature resistance: - 30° C to +100
Max. cable load	max. 10 kg per carrier WR 1-Sch max. 20 kg per carrier WST 1-Sch
for corrosive sites	use system S 1-E or K 1

Cable Carriers for round cables and hoses

WR 1-Sch

WST 1-Sch

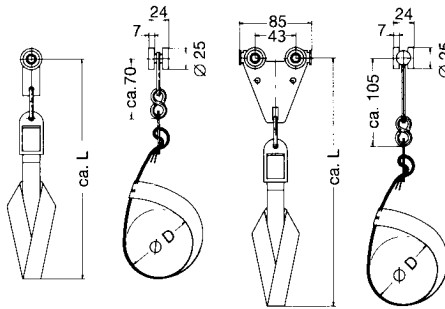

Type	Ø D mm	L mm	Weight kg	Order- No.
WR 1-Sch/ 80	80	210	0,100	312 900
WR 1-Sch/160	160	290	0,110	312 901
WST 1-Sch/ 80	80	240	0,270	312 875
WST 1-Sch/160	160	320	0,280	312 876

Installation information:

1. prepare ribbon ends as shown.
2. Epull all ends thru flap.
3. form a loop.
4. attach flap to S-hook!

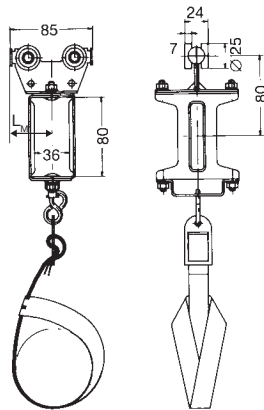
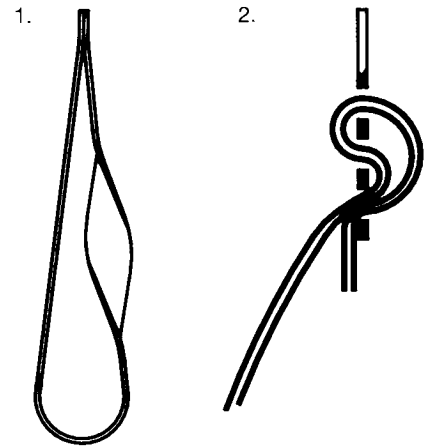

Lead Carriers for round cables and hoses

Type	for Carrier type	L _M	Weight kg	Order- No.
MST 1-Sch/ 80	WR 1-Sch/80	43	0,680	312 877
	WST 1-Sch/80			
MST 1-Sch/160	WR 1-Sch/160	43	0,690	312 878
	WST 1-Sch/160			

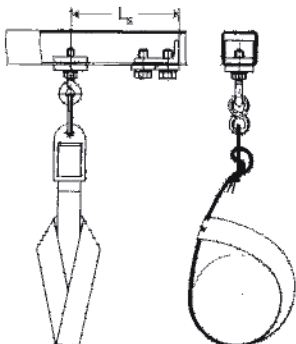

Track Clamps for round cables and hoses

Type	for Carrier type	L _E	Weight kg	Order- No.
EST 1-2-Sch/ 80	WR 1-Sch/80	110	0,140	312 879
	WST 1-Sch/80			
EST 1-2-Sch/160	WR 1-Sch/160	110	0,150	312 880
	WST 1-Sch/160			

Bumper stop PS 1, PS 1-1 or PS 1 G to be ordered separately.



S 1 CONTROL CARRIER AND ACCESSORIES



acid proof

Stainless

Control Carriers with multipole plug-in

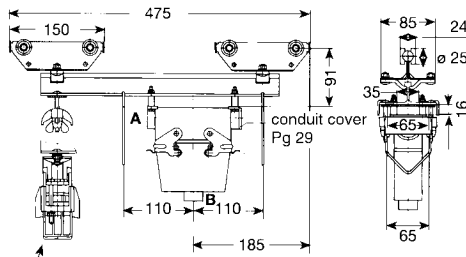

ST-ST 1 R saddle for round cable

Type (1)	plug-in-device DIN 43652	Weight kg	Order- No.
ST-ST 1/16 M	16pole	2,100	313 371
ST-ST 1/24 M	24pole	2,300	313 370
Design for round cable clamp ST-ST 1 R			
ST-ST 1 R/16 M	16pole	2,200	313 373
ST-ST 1 R/24 M	24pole	2,400	313 372

Design:

Carrier body: steel, galvanized	Support bar: aluminium
Wheels: steel ball bearings	Plug: cast iron
Cable glands for 16-poles A-Seite: M 40 x 1,5 B-Seite: M 32 x 1,5	Cable glands for 24-poles A-Seite: M 40 x 1,5 B-Seite: M 40 x 1,5
Max. cable load: 25 kg	
Temperature resistance: - 30° C to +100° C	

Control Carriers without Brake

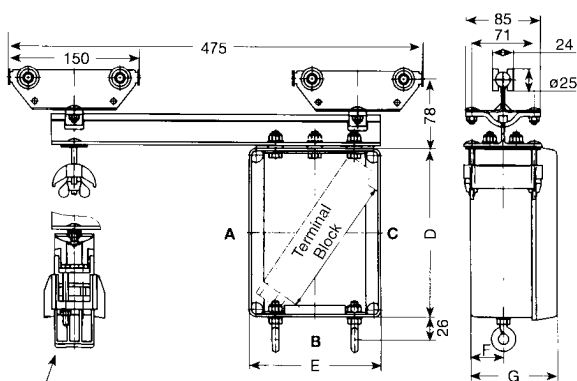

ST-ST 1 R saddle for round cable

Type(1)	mm				Weight kg	Order-No.	Type (1)	Order-No.
	D	E	F	G				
ST-ST 1/A 1	190	150	38	100	2,900	312 695	ST-ST 1-E	316 332
ST-ST 1/A 2	280	200	62	140	4,300	312 694	-	-
Design for round cable clamp ST-ST 1 R								
ST-ST 1 R/A 1	190	150	38	100	3,000	312 817	ST-ST 1 R-E	312 819
ST-ST 1 R/A 2	280	200	62	140	4,400	312 818	-	-

Design:

Carrier body: steel, galvanized	Support bar: aluminium
Wheels: steel ball bearings	Plug: PVC
Max. load: 25 kgs	
Service temperature: -30° C upto +100° C	

Attention: The connection box must be earthed with a protective earth conductor terminal Type EK 2.5 N PA!

ST-ST 1/A 1 ST-ST 1 R/A 1 ST-ST 1-E & ST-ST 1 R-E			ST-ST 1/A 2 ST-ST 1 R/A 2		
Cable glands	max. number A-Side	max. number B-Side	Cable glands	max. number A-Side	max. number B-Side
M 20 x 1,5	6	2	M 20 x 1,5	12	6
M 25 x 1,5	5	1	M 25 x 1,5	10	6
M 32 x 1,5	3	1	M 32 x 1,5	8	4
M 40 x 1,5	2	1	M 40 x 1,5	4	1
M 50 x 1,5	2	-	M 50 x 1,5	3	1
M 63 x 1,5	2	-	M 63 x 1,5	3	1

Max. length of Terminal Block A 1 = 130mm
A 2 = 220 mm

Brake spring for Control Carrier ST - ST 1

The braking device can be installed as an option.

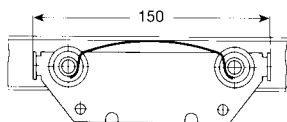

Type	Material	Weight kg	Order-No.
BF 1	stainless steel	0,007	310 860



S 1 ACCESSORIES FOR CONTROL CARRIERS

acid
proof

Stain-
less

Brake for Control Carrier

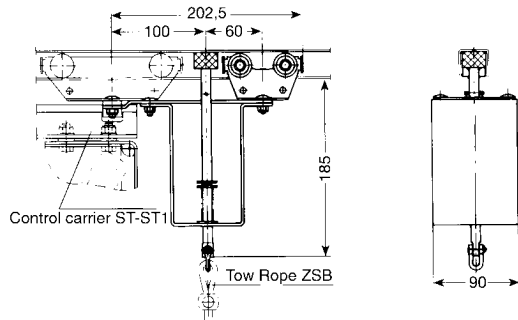

Type	Weight kg	Order-No.
BS 1	1,740	312 698

Design:
Carrier: Steel, galvanized
Wheels: Steel ball bearings

Brake for Control Carrier with AC magnet (WM)

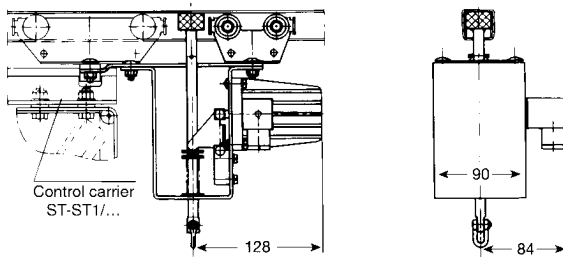

Type	Weight kg	Order-No.
BS 1-WM	2,900	312 699

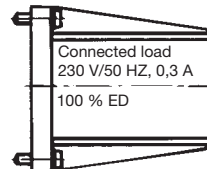

Tow Rope and Grip for Brake BS 1

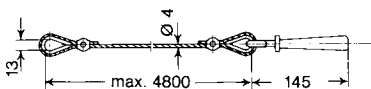

Type	Standard length- mm	Weight kg	Order-No.
ZSB	5000	0,250	310 850

Scope of delivery: hand grip, rope, rope thimble and clamp.



S 2 TRACK AND ACCESSORIES

acid
proof

Stain-
less

Track

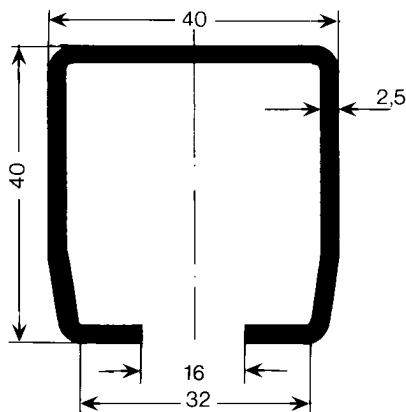

Type	S 2	S 2-E
Order-No., in 6 m sections	316 636	316 646
Order-No., in 4 m sections	316 634	316 644
Order-No. surcharge for curves	310 480	315 372
for Carriers type	WS 2 and WST 2	WST 2-E
Material	steel, galvanized	V 4 A
Supply lengths	6 m and 4 m in straight system max. 2.5 m,	
Standard support spacing	see page 47, in curves max. 1,25 m,	
Moment of inertia Jx	6,7 cm ⁴	6,7 cm ⁴
Section modulus Wx	3,1 cm ³	3,1 cm ³
Weight	2,490 kg/m	2,490 kg/m

Horizontal Curves are ready available. Consult factory for specials.

Hanger underhung

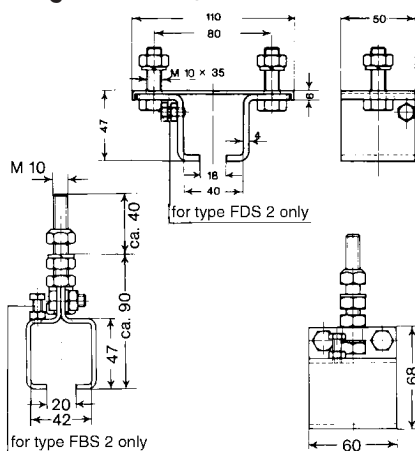

Type	Sliding-hanger ADS 2 (1)	Fixpoint-hanger FDS 2	Sliding-hanger ADS 2-E (1)	Fixpoint-hanger FDS 2-E
Order-No.	315 200	315 210	315 357	315 356
Material	steel, galvanized		V 4 A, stainless steel	
Weight	0,310 kg	0,320 kg	0,310 kg	0,320 kg

Typ	Sliding-hanger ABS 2 (1)	Fixpoint-hanger FBS 2
Order-No.	315 140	315 150
Material	steel, galvanized	
Weight	0,370 kg	0,380 kg

Hanger underhung for HK support

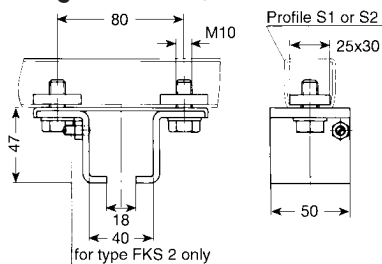

Type	Sliding-hanger AKS 2 (1)	Fixpoint-hanger FKS 2	Sliding-hanger AKS 2-E(1)	Fixpoint-hanger FKS 2-E
Order-No.	315 220	315 230	315 379	315 380
Material	steel, galvanized		V 4 A, stainless steel	
Weight	0,490 kg	0,500 kg	0,490 kg	0,500 kg

Hanger lateral

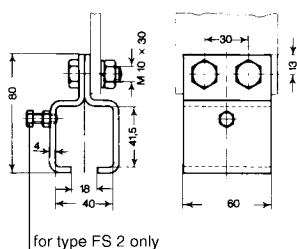

Type	Sliding-hanger AS 2 (1)	Fixpoint-hanger FS 2
Order-No.	315 030	315 040
Material	steel, galvanized	
Weight	0,470 kg	0,480 kg

Joint Clamp upto 100 m system length

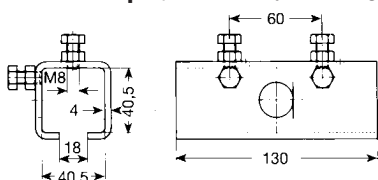

Type	VS 2	VS 2-E
Order-No.	315 050	315 355
Material	steel, galvanized	V 4 A, stainless steel
Weight	0,680 kg	0,680 kg



S 2 ACCESSORIES

acid
proof

Stain-
less

Joint Clamp, lock type (Patent pending)

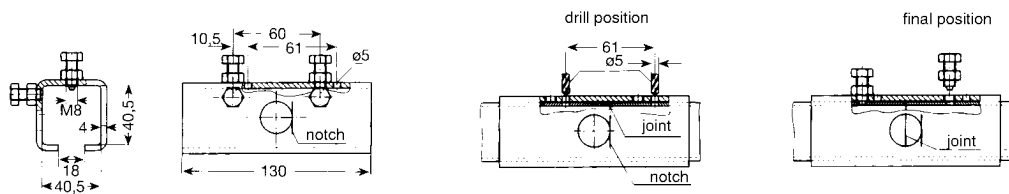

Type	VS 2-F
Order-No.	316 522
Material	steel, galvanized
Weight	0,680 kg

End Cap

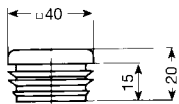

Type		K 40
Order-No.		316 449
Material		polyethylene
Weight		0,009 kg

Bumper stop

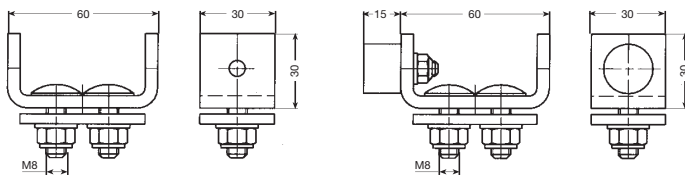

PS 2-1 (E)

PS 2-1 G

Type	PS 2-1	PS 2-1 G	PS 2-1 E
Order-No.	317 000	317 001	317 002
Material	steel, galvanized	steel, galvanized	V 4 A, stainless steel
Weight	0,220 kg	0,250 kg	0,220 kg

Flat nut w/bolt and washer

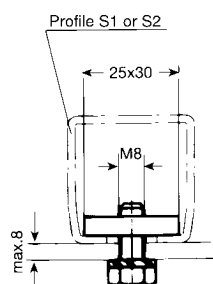

Type	M 8 x 20
Order-No.	312 600
Material	Stahl, verzinkt
Weight	0,044 kg



S 2 ACCESSORIES

acid
proof

Stain-
less

Standard Brackets

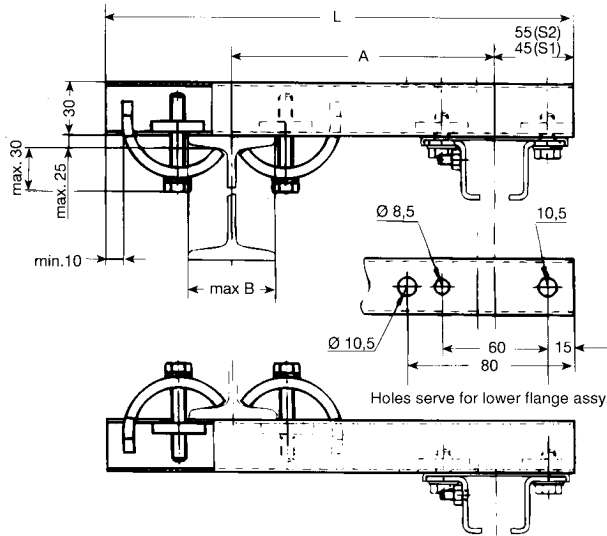

Choose dim. A per local requirements and make sure that hoist wheels have enough clearance.

Select next larger size bracket when your I-Beam dim. B is more than 210 mm and refer to page 23 for heavy duty brackets.

Type	Material	Weight kg	A (adjustable) mm	L mm	max B mm	Order-No.	Type	Mat.	Order-No.
HK 200	steel galvanized	0,980	200	400	210 ⁽¹⁾	310 220	HK 200-E	stainl. steel V 4 A	312 510
HK 300		1,130	300	500	210 ⁽¹⁾	310 230	HK 300-E		312 511
HK 400		1,290	400	600	210 ⁽¹⁾	310 240	HK 400-E		312 512
HK 500		1,430	500	700	210 ⁽¹⁾	310 250	HK 500-E		312 513

Scope of supply: 1 pair of claws and rail short length S1.
Hangers AKS 2 and FKS 2 to be ordered separately.

Bracket Bars for HK

Type	Material	Weight kg	L mm	Order-No.	Type	Mat.	Order-No.
S 1-400	steel galvanized	0,620	400	310 600	S 1E-400	stainl. steel V 4 A	312 515
S 1-500		0,780	500	310 610	S 1E-500		312 516
S 1-600		0,930	600	310 620	S 1E-600		312 517
S 1-700		1,090	700	310 630	S 1E-700		312 518

Claws for HK

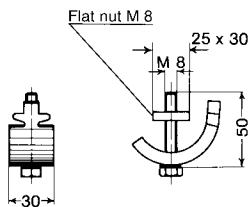

Range area 0-20 mm

Type	SP	SP-E
Order-No.	310 390	312 514
Material	steel, galvanized	V 4 A, stainless steel
Weight	0,200 kg	0,200 kg

Flat nut M 8 separately available.
Order-No. 310 955

Flat nut M 8 E stainless
separately available.
Order-No. 312 545

Support Attachment for HK

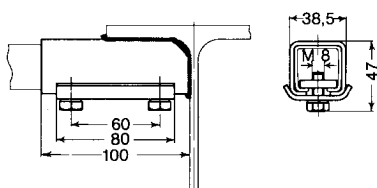

Type	AH 1
Order-No.	310 400
Material	steel
Weight	0,460 kg

Bracket bar sections and hangers to be ordered separately..



S 2 ACCESSORIES

acid proof

Stainless

Bracket Bars for HK heavy duty

The track sections are provided with borings to fix the support hangers at the bottom flange of the track profile.

Type	Material	Weight kg	Dim. L mm	Order-No.	Type	Werkstoff	Order-No.
S 2- 400	steel galvanize	0,996	400	315 402	S 2E- 400	V 4 A	316 513
S 2- 500		1,245	500	315 403	S 2E- 500		316 514
S 2- 600		1,494	600	315 404	S 2E- 600		316 515
S 2- 700		1,743	700	315 405	S 2E- 700		316 516
S 2- 800		1,992	800	315 406	S 2E- 800		316 517
S 2- 900		2,241	900	315 407	S 2E- 900		316 518
S 2-1000		2,490	1000	315 408	S 2E-1000		316 519
S 2-1100		2,739	1100	315 409	S 2E-1100		316 520
S 2-1200		2,988	1200	315 410	S 2E-1200		316 521

General Assembly of Heavy Duty Bracket

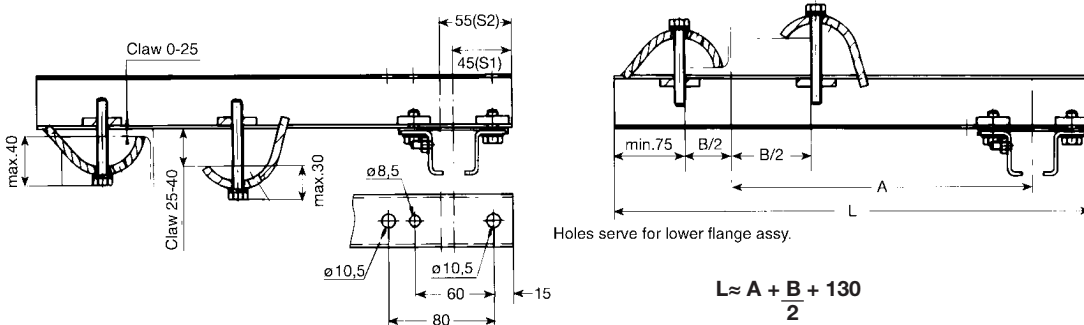

Dimension A is based on the width of the current consumer (e.g. the trolley). Please consider the running wheel diameter (flange) of the chassis in overhead monorails.

Claws for HK heavy duty

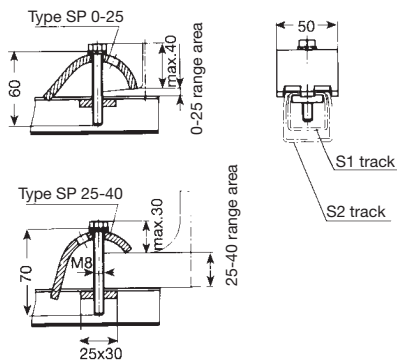

Type	SP 0-25	SP 0-25-E
Order-No.	312 643	316 690
Material	steel, galvanized	V 4 A, stainless steel
Weight	0,286 kg	0,286 kg

Type	SP 25-40	SP 25-40-E
Order-No.	312 644	316 695
Material	steel, galvanized	V 4 A, stainless steel
Weight	0,287 kg	0,287 kg

Support Attachment for HK heavy duty

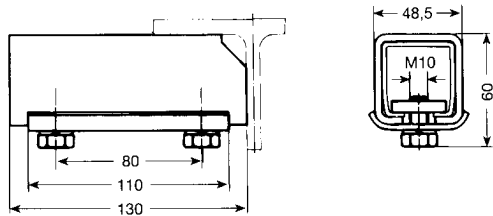

Type	AH 2
Order-No.	310 989
Material	steel
Weight	0,940 kg

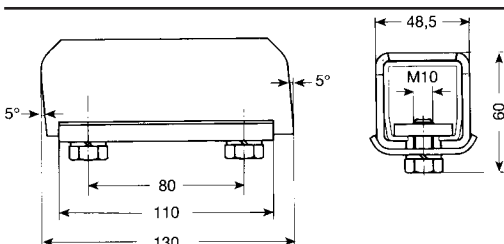

Type	AH 2-2
Order-No.	312 648
Material	steel
Weight	0,854 kg



S2 CABLE CARRIERS AND ACCESSORIES – Steel type –



hex. nut version



quick-set nut version

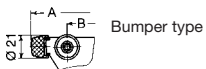

Bumper type

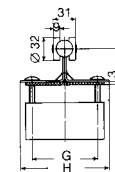
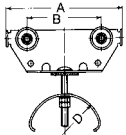

Engineering Data

Type	WST 2 F (für Flachleitungen)	
Wheels	hardened and galvanized steel rollers with precision ball bearing, sealed against dust and splash water – <u>2 metal sealings</u> Temperature resistance Lub. Grease of wheels –30° C to +125° C Travelling speed ca. 100 m/min.	Polyamid rollers on bushed bearings ca. 60 m/min.
Material	Carrier body: steel galvanized Support saddle galvanized steel Bumper: Neoprene Hardware galvanized Temperatur resistance: – 30° C to +100° C	with patented nut support saddle Polyamid
Max. cable load	max. 28 kg per carrier	max. 12 kg per carrier
Depth of cable loop	not in curves	not in curves
for corrosive sites	use system S 2-E	

Cable carriers for flatform cables not suitable for strain relief

Type	max. thckn. of individual cable mm	max. clamping capacity in mm height x width	A	B	Ø D	G	H	Weight kg	with patented nut Order-No. (2)	Order-No.	Type	with patented nut Order-No. (2)	Order-No.
WST 2 F/ 85 (1)	8	17 x 65	85	43	50	85	85	0,460	316 493	316 170	WST 2 F/ 85 K (1)	317 008	317 018
WST 2 F/ 85 P		29 x 65	110					0,470	316 494	316 180	WST 2 F/ 85 KP	317 009	317 019
WST 2 F/125-50 (1)		37 x 65	125	80				97	0,560	316 495	315 381	WST 2 F/125-50 K (1)	317 010
WST 2 F/125-50 P	50 x 65	150	0,570		316 496	315 382	WST 2 F/125-50 KP		317 011	317 021			
WST 2 F/125 (1)	10	22 x 65	125	80	0,630	316 497	316 190		WST 2 F/125 K (1)	317 012	317 022		
WST 2 F/125 P		34 x 65	150		0,640	316 498	316 200	WST 2 F/125 KP	317 013	317 023			
WST 2 F/150-50 (1)	8	50 x 65	150	50	71	85	0,590	316 499	315 383	WST 2 F/150-50 K (1)	317 014	317 024	
WST 2 F/150-50 P		62 x 65	175				0,600	316 500	315 384	WST 2 F/150-50 KP	317 015	317 025	
WST 2 F/150-80 (1)	10	35 x 65	150	80			0,660	316 501	315 385	WST 2 F/150-80 K (1)	317 016	317 026	
WST 2 F/150-80 P		47 x 65	175		0,670	316 502	315 386	WST 2 F/150-80 KP	317 017	317 027			
WST 2 F/150 (1)	12	25 x 65	150	105	100	85	0,700		316 210	WST 2 F/150 K (1)		317 028	
WST 2 F/150 P		37 x 65	175				0,710		316 220	WST 2 F/150 KP		317 029	
WST 2 F/200-100 (1)		50 x 65	200				0,800		316 576	WST 2 F/200-100 K (1)		317 030	
WST 2 F/200-100 P		62 x 65	225				0,810		316 577	WST 2 F/200-100 KP		317 031	

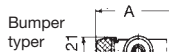

Bumper type

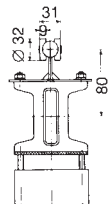
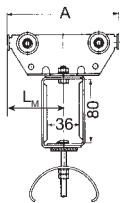

Lead Carriers for flatform cables

Type	for Carrier type	Lm	A mm	Weight kg	with patented Order-No. (2)	Order-No.	Type	with patented Order-No. (2)	Order-No.
MST 2 F/ 85 (1)	WST 2 F/ 85	43	85	0,830	316 503	316 230	MST 2 F/ 85 K (1)	317 032	317 042
MST 2 F/ 85 P	WST 2 F/ 85 P	55	110	0,840	316 504	316 240	MST 2 F/ 85 KP	317 033	317 043
MST 2 F/125-50 (1)	WST 2 F/125-50	63	125	0,940	316 505	315 389	MST 2 F/125-50 K (1)	317 034	317 044
MST 2 F/125-50 P	WST 2 F/125-50 P	75	150	0,950	316 506	315 390	MST 2 F/125-50 KP	317 035	317 045
MST 2 F/125 (1)	WST 2 F/125	63	125	1,010	316 507	316 250	MST 2 F/125 K (1)	317 036	317 046
MST 2 F/125 P	WST 2 F/125 P	75	150	1,020	316 508	316 260	MST 2 F/125 KP	317 037	317 047
MST 2 F/150-50 (1)	WST 2 F/150-50	75	150	0,960	316 509	315 391	MST 2 F/150-50 K (1)	317 038	317 048
MST 2 F/150-50 P	WST 2 F/150-50 P	88	175	0,970	316 510	315 392	MST 2 F/150-50 KP	317 039	317 049
MST 2 F/150-80 (1)	WST 2 F/150-80	75	150	1,030	316 511	315 393	MST 2 F/150-80 K (1)	317 040	317 050
MST 2 F/150-80 P	WST 2 F/150-80 P	88	175	1,040	316 512	315 394	MST 2 F/150-80 KP	317 041	317 051
MST 2 F/150 (1)	WST 2 F/150	75	150	1,070		316 270	MST 2 F/150 K (1)		317 052
MST 2 F/150 P	WST 2 F/150 P	88	175	1,080		316 280	MST 2 F/150 KP		317 053
MST 2 F/200-100 (1)	WST 2 F/200-100	100	200	1,170		316 578	MST 2 F/200-100 K (1)		317 054
MST 2 F/200-100 P	WST 2 F/200-100 P	113	225	1,180		316 579	MST 2 F/200-100 KP		317 055

Track clamps for flatform cables

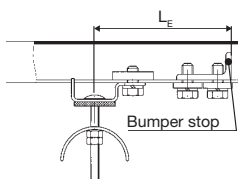

Bumper stop PS 2-1 (PS 2-1 G, PS 2-1-E) to be ordered separately.

Type	for Carrier type	L _E mm	Weight kg	with patented Order-No. (2)	Best.-Nr.
EST 1-2 F/ 85	WST 2 F/ 85 (K) (P)	150	0,290	313 304	313 315
	WST 2 F/125-50 (K) (P)				
	WST 2 F/150-50 (K) (P)				
EST 1-2 F/125	WST 2 F/125 (K) (P)	150	0,370	313 308	313 316
	WST 2 F/150-80 (K) (P)				
EST 1-2 F/150	WST 2 F/150 (K) (P)	150	0,410		313 317
EST 1-2 F/100-2	WST 2 F/200-100 (K) (P)	190	0,410		313 318

(1) w/o Bumper

(2) with patented nut use suffix PM e. g. WST 2/F 85-PM.



S2 CABLE CARRIERS AND ACCESSORIES – Steel type–



Engineering Data

Type	WST 2 R	
Wheels	hardened and galvanized steel rollers with precision ball bearing, sealed against dust and splash water Temperature resistance Lub. Grease of wheels -30° C to +125° C, Travelling speed ca. 100 m/min.	Kunststoffauflrollen mit Gleitlager ca. 60 m/min.
Material	Carrier body: steel galvanized Support saddle: Polyamid Bumper: Neoprene Hardware galvanized Temperatur resistance: - 30° C to +100° C	
Max. cable load	max. 22 kg per carrier	max. 12 kg je Leitungswagen
Depth of cable loop	not in curves	not in curves
for corrosive sites	use system S 2-E	

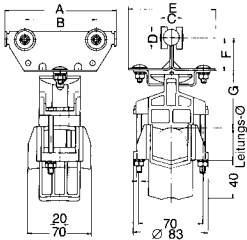
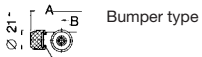

Cable carriers for round cable and hoses not suitable for strain relief

Type	Cable-Ø	mm							Weight kg	Order-No.	Type	Order-No.
		A	B	C	D	E	F	G				
WST 2 R/ 85 ⁽¹⁾	5 mm bis 38 mm	85	43	31	32	85	36	99	0,530	316 416	WST 2 R/ 85 K ⁽¹⁾	317 056
WST 2 R/ 85 P		110							0,550	316 417	WST 2 R/ 85 KP	317 057
WST 2 R/125 ⁽¹⁾		125	80	31	32	97	36	99	0,630	316 418	WST 2 R/125 K ⁽¹⁾	317 058
WST 2 R/125 P		150							0,650	316 419	WST 2 R/125 KP	317 059

Lead carriers for round cables and hoses

Bumper type

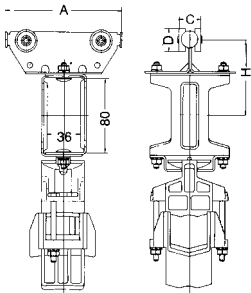

Type	for Carrier type	mm				Weight kg	Order-No.	Type	Order-No.
		A	C	D	H				
MST 2 R/ 85 ⁽¹⁾	WST 2 R/ 85	85	31	32	80	0,890	316 420	MST 2 R/85 K ⁽¹⁾	317 060
MST 2 R/ 85 P	WST 2 R/ 85 P	110				0,910	316 421	MST 2 R/85 KP ⁽¹⁾	317 061
MST 2 R/125 ⁽¹⁾	WST 2 R/125	125				0,990	316 422	MST 2 R/125 K ⁽¹⁾	317 062
MST 2 R/125 P	WST 2 R/125 P	150				1,010	316 423	MST 2 R/125 KP ⁽¹⁾	317 063

Track clamp for round cables and hoses

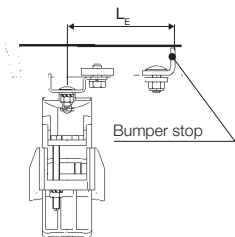

Type	for Carrier type	L _E mm	Weight kg	Order-No.
EST 1-2 R	WST 2 R (all types)	160	0,338	313 321

Pufferanschlag PS 2-1 (PS 2-1 G) ist gesondert zu bestellen.

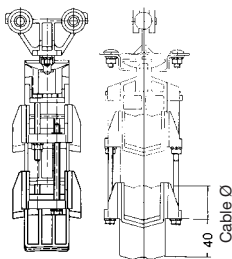

Support saddle for round cables and hoses

for additional tier

Type	for Carrier typ	Weight kg	Order-No.
LAR	WST 2 R (all types)	0,110	312 500

⁽¹⁾ w/o Bumper



S 2 CABLE CARRIERS - Steel type -



Engineering Data

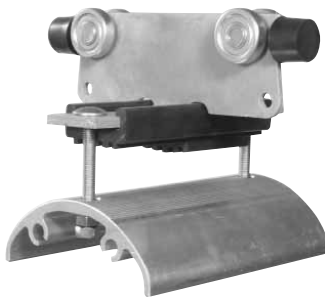

Typ	WST 2 FR
Wheels	hardened and galvanized steel rollers with precision ball bearing, sealed against dust and splash water – 2 metal sealings Temperature resistance Lub. Grease of wheels -30° C to +125° C Travelling speed ca. 100 m/min. To be used with adequate tension relief ropes.
Material	Carrier body: steel galvanized Support saddle: aluminium Bumper: EPDM Hardware galvanized Temperatur resistance: - 30° C to +100° C
Max. cable load	max. 35 kg per carrier
Depth of cable loop	in curves max. 0,3 x track radius, consider tension relief
for corrosive sites	use system WST 2 FR-E

Cable carrier WST 2 FR:

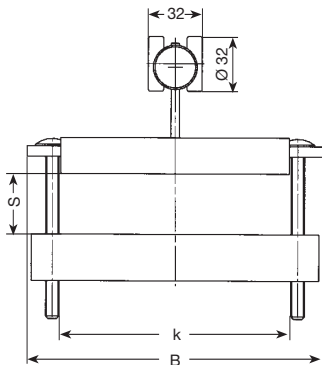
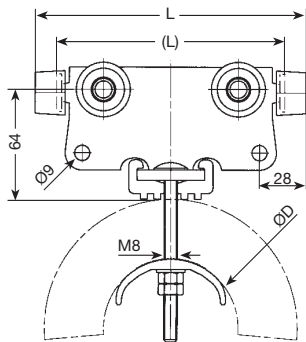

Collecting clamp for round cables:
Extension rubber profile can be ordered per meter (order no.: 348 845)

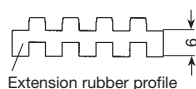
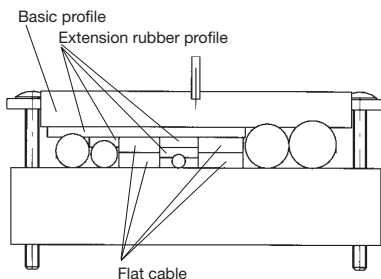

Type	max. clamping capacity in mm height x width	L mm	(L) mm	B mm	D mm	Weight kg	Order-No.
WST 2 FR/125- 80 B175 P	18 x 130	125	-	175	80	1,09	316 895
WST 2 FR/125- 80 B225 P	18 x 180	125	-	225	80	1,22	316 896
WST 2 FR/135- 80 B175	22 x 130	-	135	175	80	1,17	316 897
WST 2 FR/135- 80 B225	22 x 180	-	135	225	80	1,30	316 898
WST 2 FR/160- 80 B175 P	35 x 130	160	-	175	80	1,17	316 899
WST 2 FR/160- 80 B225 P	35 x 180	160	-	225	80	1,30	316 900
WST 2 FR/160-100 B175 P	25 x 130	160	-	175	100	1,25	316 901
WST 2 FR/160-100 B225 P	25 x 180	160	-	225	100	1,42	316 902
WST 2 FR/175- 80 B175	42 x 130	-	175	175	80	1,27	316 903
WST 2 FR/175- 80 B225	42 x 180	-	175	225	80	1,40	316 904
WST 2 FR/175-100 B175	32 x 130	-	175	175	100	1,35	316 905
WST 2 FR/175-100 B225	32 x 180	-	175	225	100	1,52	316 906
WST 2 FR/200- 80 B175 P	55 x 130	200	-	175	80	1,27	316 907
WST 2 FR/200- 80 B225 P	55 x 180	200	-	225	80	1,40	316 908
WST 2 FR/200-100 B175 P	45 x 130	200	-	175	100	1,35	316 909
WST 2 FR/200-100 B225 P	45 x 180	200	-	225	100	1,52	316 910
WST 2 FR/200-140 B175 P	25 x 130	200	-	175	140	1,59	316 911
WST 2 FR/200-140 B225 P	25 x 180	200	-	225	140	1,83	316 912
WST 2 FR/225-100 B175	58 x 130	-	225	175	100	1,47	316 913
WST 2 FR/225-100 B225	58 x 180	-	225	225	100	1,64	316 914
WST 2 FR/225-140 B175	38 x 130	-	225	175	140	1,71	316 915
WST 2 FR/225-140 B225	38 x 180	-	225	225	140	1,95	316 916
WST 2 FR/225-170 B175	22 x 130	-	225	175	170	1,77	316 917
WST 2 FR/225-170 B225	22 x 180	-	225	225	170	2,02	316 918
WST 2 FR/250-100 B175 P	70 x 130	250	-	175	100	1,47	316 919
WST 2 FR/250-100 B225 P	70 x 180	250	-	225	100	1,64	316 920
WST 2 FR/250-140 B175 P	50 x 130	250	-	175	140	1,71	316 921
WST 2 FR/250-140 B225 P	50 x 180	250	-	225	140	1,95	316 922
WST 2 FR/250-170 B175 P	35 x 130	250	-	175	170	1,77	316 923
WST 2 FR/250-170 B225 P	35 x 180	250	-	225	170	2,02	316 924
WST 2 FR/265-140 B175	58 x 130	-	265	175	140	1,81	316 925
WST 2 FR/265-140 B225	58 x 180	-	265	225	140	2,05	316 926
WST 2 FR/265-170 B175	42 x 130	-	265	175	170	1,87	316 927
WST 2 FR/265-170 B225	42 x 180	-	265	225	170	2,12	316 928
WST 2 FR/290-140 B175 P	70 x 130	290	-	175	140	1,81	316 929
WST 2 FR/290-140 B225 P	70 x 180	290	-	225	140	2,05	316 930
WST 2 FR/290-170 B175 P	55 x 130	290	-	175	170	1,87	316 931
WST 2 FR/290-170 B225 P	55 x 180	290	-	225	170	2,12	316 932
WST 2 FR/300-170 B175	60 x 130	-	300	175	170	1,95	316 933
WST 2 FR/300-170 B225	60 x 180	-	300	225	170	2,20	316 934
WST 2 FR/300-230 B175	30 x 130	-	300	175	230	2,90	317 074
WST 2 FR/300-230 B225	30 x 180	-	300	225	230	3,40	317 075
WST 2 FR/325-170 B175 P	72 x 130	325	-	175	170	1,95	316 935
WST 2 FR/325-170 B225 P	72 x 180	325	-	225	170	2,20	316 936
WST 2 FR/325-230 B175 P	42 x 130	325	-	175	230	2,90	317 076
WST 2 FR/325-230 B225 P	42 x 180	325	-	225	230	3,40	317 077



S 2 LEAD CARRIERS – Steel type –

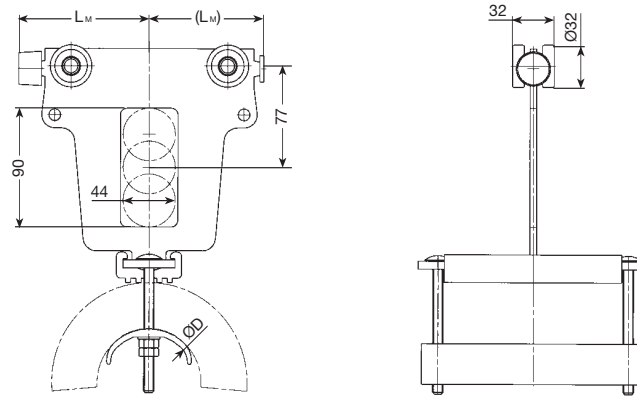

Lead carriers MST 2 FR

Type	for Cable carrier	Lm mm	(Lm) mm	D mm	Weight kg	Order- No.
MST 2 FR/175- 80 B175	WST 2 FR/135- 80 B175 WST 2 FR/175- 80 B175	–	88	80	1,51	316 952
MST 2 FR/175- 80 B225	WST 2 FR/135- 80 B225 WST 2 FR/175- 80 B225	–	88	80	1,65	316 953
MST 2 FR/175-100 B175	WST 2 FR/175-100 B175	–	88	100	1,59	316 954
MST 2 FR/175-100 B225	WST 2 FR/175-100 B225	–	88	100	1,77	316 955
MST 2 FR/200- 80 B175 P	WST 2 FR/125- 80 B175 P WST 2 FR/160- 80 B175 P WST 2 FR/200- 80 B175 P	100	–	80	1,51	316 956
MST 2 FR/200- 80 B225 P	WST 2 FR/125- 80 B225 P WST 2 FR/160- 80 B225 P WST 2 FR/200- 80 B225 P	100	–	80	1,65	316 957
MST 2 FR/200-100 B175 P	WST 2 FR/160-100 B175 P WST 2 FR/200-100 B175 P	100	–	100	1,59	316 958
MST 2 FR/200-100 B225 P	WST 2 FR/160-100 B225 P WST 2 FR/200-100 B225 P	100	–	100	1,77	316 959
MST 2 FR/200-140 B175 P	WST 2 FR/200-140 B175 P	100	–	140	1,83	316 960
MST 2 FR/200-140 B225 P	WST 2 FR/200-140 B225 P	100	–	140	2,08	316 961
MST 2 FR/300-100 B175	WST 2 FR/225-100 B175	–	150	100	1,93	316 962
MST 2 FR/300-100 B225	WST 2 FR/225-100 B225	–	150	100	2,11	316 963
MST 2 FR/300-140 B175	WST 2 FR/225-140 B175 WST 2 FR/265-140 B175	–	150	140	2,17	316 964
MST 2 FR/300-140 B225	WST 2 FR/225-140 B225 WST 2 FR/265-140 B225	–	150	140	2,42	316 965
MST 2 FR/300-170 B175	WST 2 FR/225-170 B175 WST 2 FR/265-170 B175 WST 2 FR/300-170 B175	–	150	170	2,23	316 966
MST 2 FR/300-170 B225	WST 2 FR/225-170 B225 WST 2 FR/265-170 B225 WST 2 FR/300-170 B225	–	150	170	2,49	316 967
MST 2 FR/300-230 B175	WST 2 FR/300-230 B175	–	150	230	3,17	317 078
MST 2 FR/300-230 B225	WST 2 FR/300-230 B225	–	150	230	3,70	317 079
MST 2 FR/325-100 B175 P	WST 2 FR/250-100 B175 P	162	–	100	1,93	316 968
MST 2 FR/325-100 B225 P	WST 2 FR/250-100 B225 P	162	–	100	2,11	316 969
MST 2 FR/325-140 B175 P	WST 2 FR/250-140 B175 P WST 2 FR/290-140 B175 P	162	–	140	2,17	316 970
MST 2 FR/325-140 B225 P	WST 2 FR/250-140 B225 P WST 2 FR/290-140 B225 P	162	–	140	2,42	316 971
MST 2 FR/325-170 B175 P	WST 2 FR/250-170 B175 P WST 2 FR/290-170 B175 P WST 2 FR/325-170 B175 P	162	–	170	2,23	316 972
MST 2 FR/325-170 B225 P	WST 2 FR/250-170 B225 P WST 2 FR/290-170 B225 P WST 2 FR/325-170 B225 P	162	–	170	2,49	316 973
MST 2 FR/325-230 B175 P	WST 2 FR/325-230 B175 P	162	–	230	3,17	317 080
MST 2 FR/325-230 B225 P	WST 2 FR/325-230 B225 P	162	–	230	3,70	317 081



S 2 TRACK CLAMPS – Steel type –

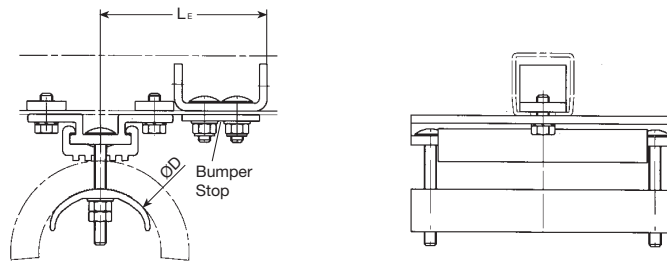

Track clamps EST 2 FR

Bumper stop PS 2-1; PS 2-1 G to be ordered separately

Type	for Cable carrier	L _e mm	D mm	Weight kg	Order- No.
EST 2 FR/ 80 B175	WST 2 FR/125- 80 B175 P	165	80	0,78	316 986
	WST 2 FR/135- 80 B175	165			
	WST 2 FR/160- 80 B175 P	165			
	WST 2 FR/175- 80 B175	165			
	WST 2 FR/200- 80 B175P	165			
EST 2 FR/ 80 B225	WST 2 FR/125- 80 B225 P	165	80	0,92	316 987
	WST 2 FR/135- 80 B225	165			
	WST 2 FR/160- 80 B225 P	165			
	WST 2 FR/175- 80 B225	165			
	WST 2 FR/200- 80 B225 P	165			
EST 2 FR/100 B175	WST 2 FR/160-100 B175 P	165	100	0,86	316 988
	WST 2 FR/175-100 B175	165			
	WST 2 FR/200-100 B175P	165			
	WST 2 FR/225-100 B175	170			
	WST 2 FR/250-100 B175 P	180			
EST 2 FR/100 B225	WST 2 FR/160-100 B225 P	165	100	1,04	316 989
	WST 2 FR/175-100 B225	165			
	WST 2 FR/200-100 B225 P	165			
	WST 2 FR/225-100 B225	170			
	WST 2 FR/250-100 B225 P	180			
EST 2 FR/140 B175	WST 2 FR/200-140 B175 P	165	140	1,10	316 990
	WST 2 FR/225-140 B175	170			
	WST 2 FR/250-140 B175 P	180			
	WST 2 FR/265-140 B175	190			
	WST 2 FR/290-140 B175 P	200			
EST 2 FR/140 B225	WST 2 FR/200-140 B225 P	165	140	1,35	316 991
	WST 2 FR/225-140 B225	170			
	WST 2 FR/250-140 B225 P	180			
	WST 2 FR/265-140 B225	190			
	WST 2 FR/290-140 B225 P	200			
EST 2 FR/170 B175	WST 2 FR/225-170 B175	170	170	1,16	316 992
	WST 2 FR/250-170 B175 P	180			
	WST 2 FR/265-170 B175	190			
	WST 2 FR/290-170 B175 P	200			
	WST 2 FR/300-170 B175	205			
	WST 2 FR/325-170 B175 P	220			
EST 2 FR/170 B225	WST 2 FR/225-170 B225	170	170	1,42	316 993
	WST 2 FR/250-170 B225 P	180			
	WST 2 FR/265-170 B225	190			
	WST 2 FR/290-170 B225 P	200			
	WST 2 FR/300-170 B225	205			
	WST 2 FR/325-170 B225 P	220			
EST 2 FR/230 B175	WST 2 FR/300-230 B175	205	230	2,10	317 082
	WST 2 FR/325-230 B175 P	220			
EST 2 FR/230 B225	WST 2 FR/300-230 B225	205	230	2,62	317 083
	WST 2 FR/325-230 B225 P	220			



S2-E CABLE CARRIERS AND ACCESSORIES

– Stainless steel type – **acid proof**

**Stain-
less**

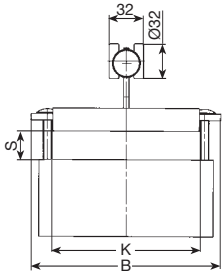
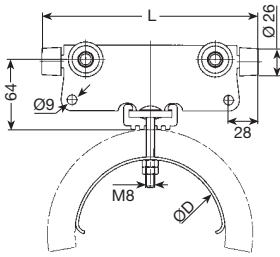

Engineering Data

Type	WST 2 FR E
Wheels	stainless steel rollers with precision ball bearing, sealed against dust and splash water. Temperature resistance Lub. Grease of wheels -30°C to +150°C, Travelling speed ca. 100 m/min.
Material	Wagenkörper: V4A Leitungsauflage: V4A Puffer: EPDM Schrauben und Muttern: V4A Gebrauchstemperatur: -30° C bis +80° C
Max. cable load	max. 20 kg per Carrier

Cable carrier WST 2 FR E

Type	max. clamping capacity in mm height x width	L mm	B mm	D mm	Weight kg	Order-No.
WST 2 FR/200-140 B175-E P	25 x 135	200	175	140	1,80	316 939
WST 2 FR/250-140 B175-E P	50 x 135	250	175	140	1,90	316 945
WST 2 FR/250-170 B175-E P	35 x 135	250	175	170	2,23	316 947

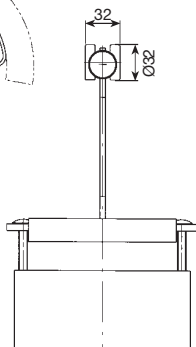
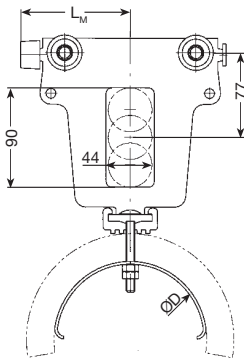

Lead carriers MST 2 FR E

Type	for Cable carrier	L _M mm	D mm	Weight kg	Order-No.
MST 2 FR/200-140 B175-E P	WST 2 FR/200-140 B175-E P	100	140	2,03	316 976
MST 2 FR/325-140 B175-E P	WST 2 FR/250-140 B175-E P	162	140	2,37	316 982
MST 2 FR/325-170 B175-E P	WST 2 FR/250-170 B175-E P	162	170	2,70	316 984

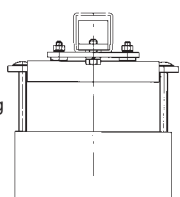
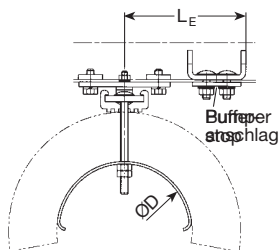

Track clamps EST 2 FR E

Bumper stop PS 2-1 E to be ordered separately

Type	for Cable carrier	L _E mm	D mm	Weight kg	Order-No.
EST 2 FR/ 140 B175-E	WST 2 FR/200-140 B175-E P	165	140	1,30	316 996
	WST 2 FR/250-140 B175-E P	180			
EST 2 FR/ 170 B175-E	WST 2 FR/250-170 B175-E P	180	170	1,62	316 998



S 2 CABLE CARRIERS AND ACCESSORIES

- Steel type -



Engineering Data

Typ	WR 2-Sch, WST 2-Sch	
Wheels	ball bearings sealed against dust and splash water – 2 metal sealings hardened, galvanized, Temperature resistance Lub. grease of wheels: - 30° C to + 125° C, Travelling speed: ca. 80 m/min.	Polyamid rollers on bushed bearings ca. 60 m/min..
Material	Carrier body: steel, galvanized S-Hook: steel, galvanized Cable-loop: Polyamid Hardware: galvanized Temperature resistance: - 30° C to +100° C	
Max. cable load	max. 15 kg per carrier WR 2-Sch max. 30 kg per carrier WST 2-Sch	max. 6 kg p.c. WR 2-Sch-K max. 12 kg p.c. WST 2-Sch-K
for corrosive sites	use system S 2-E	

Cable Carriers for round cables and hoses

WR 2-Sch

WST 2-Sch

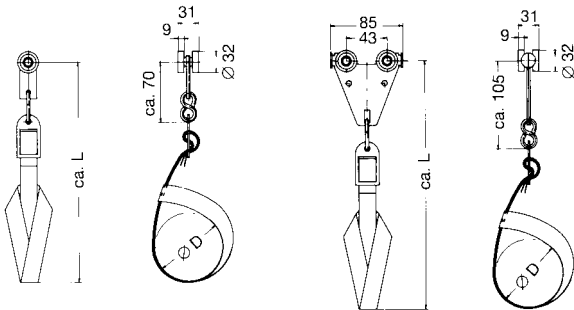

Type	Ø D mm	L mm	Weight kg	Order-No.	Type	Order-No.
WR 2-Sch/ 80	80	210	0,160	316 600	WR 2-Sch/ 80 K	317 064
WR 2-Sch/160	160	290	0,170	316 601	WR 2-Sch/160 K	317 065
WST 2-Sch/ 80	80	240	0,370	316 550	WST 2-Sch/ 80 K	317 066
WST 2-Sch/160	160	320	0,380	316 555	WST 2-Sch/160 K	317 067

Installation information:

1. prepare ribbon ends as shown
2. pull all ends thru flap.
3. form a loop
4. attach flap to S-hook

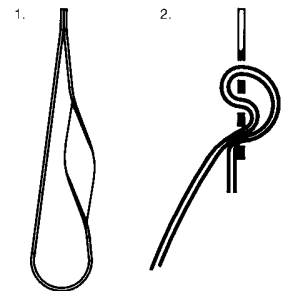

Lead Carriers for round cables and hoses

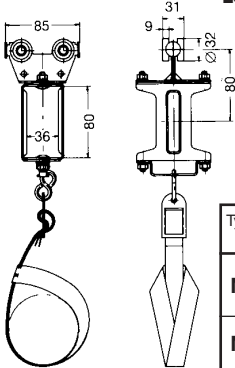

Type	for Carrier type	Weight kg	Order-No.	Type	Order-No.
MST 2-Sch/ 80	WR 2-Sch/ 80	0,780	316 556	MST 2-Sch/ 80 K	317 068
	WST 2-Sch/ 80				
MST 2-Sch/160	WR 2-Sch/160	0,790	316 557	MST 2-Sch/160 K	317 069
	WST 2-Sch/160				

Track Clamps for round cables and hoses

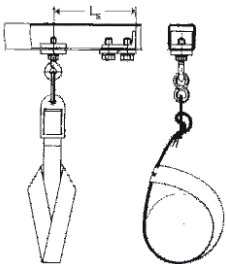

Bumper stop PS 2-1 or PS 2-1 G to be ordered separately.

Type	for Carrier type	L _E mm	Weight kg	Order-No.
EST 1-2-Sch/ 80	WR 2-Sch/ 80	110	0,140	312 879
	WST 2-Sch/ 80			
EST 1-2-Sch/160	WR 2-Sch/160	110	0,150	312 880
	WST 2-Sch/160			



S 2 CONTROL CARRIERS AND BRAKE SPRING



acid proof

Stain-less

Control Carriers with multipole plug-in

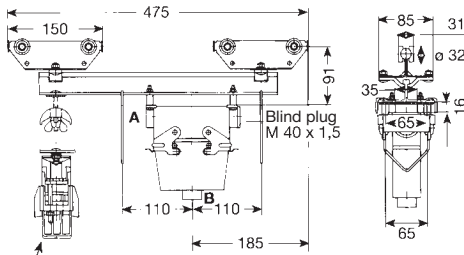

Design for round cable clamp ST-ST 2 R

Type (1)	plug-in-device DIN 43652	Weight kg	Order- No.
ST-ST 2/16 M	16pole	2,300	317 144
ST-ST 2/24 M	24pole	2,500	317 143
Design for round cable clamp ST-ST 2 R			
ST-ST 2 R/16 M	16pole	2,400	317 146
ST-ST 2 R/24 M	24pole	2,600	317 145

Design:

Carrier body: steel, galvanized Support bar: aluminium
Wheels: steel ball bearings Plug: cast iron

Cable glands for 16-poles for 24-poles
A-Side: Pg 29 A-Side: Pg 29
B-Side: Pg 21 B-Side: Pg 29

Max. cable load: 25 kg
Temperature resistance: - 30° C to +100° C

Control Carriers without Brake

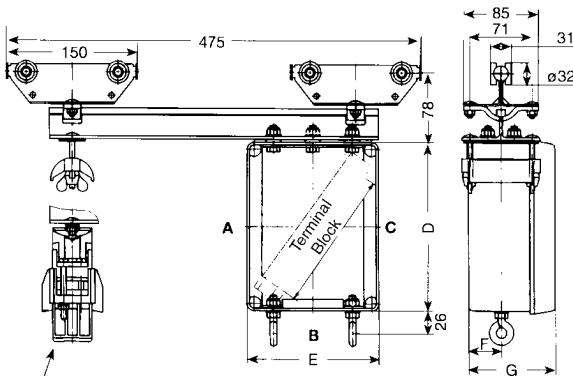

ST-ST 2 R saddle for round cable

Type (1)	D	E	F	G	Weight kg	Order-No.
	mm					
ST-ST 2/A 1	190	150	38	100	3,100	316 456
ST-ST 2/A 2	280	200	62	140	4,500	316 455
Design for round cable clamp ST-ST 2 R						
ST-ST 2 R/A 1	190	150	38	100	3,200	316 525
ST-ST 2 R/A 2	280	200	62	140	4,600	316 526

Design:

Carrier body: steel, galvanized Support bar: aluminium
Wheels: steel ball bearings Plug: PVC

Max. cable load: 25 kg
Temperature resistance: - 30° C to +100° C

Attention: The connection box must be earthed with a protective earth conductor terminal Type EK 2.5 N PA!

ST-ST 2/A 1 ST-ST 2 R/A 1			ST-ST 2/A 2 ST-ST 2 R/A 2		
Cable glands	max. number A-Side	max. number B-Side	Cable glands	max. number A-Side	max. number B-Side
M 20 x 1,5	6	2	M 20 x 1,5	12	6
M 25 x 1,5	5	1	M 25 x 1,5	10	6
M 32 x 1,5	3	1	M 32 x 1,5	8	4
M 40 x 1,5	2	1	M 40 x 1,5	4	1
M 50 x 1,5	2	-	M 50 x 1,5	3	1
M 63 x 1,5	2	-	M 63 x 1,5	3	1

Max. length of Terminal Block A1 = 130 mm
A2 = 220 mm

Brake spring for Control Carrier ST - ST 2

The braking device can be installed as an option.

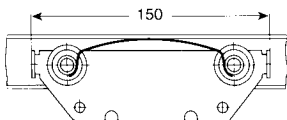

Type	Material	Weight kg	Order-No.
BF 2-2	stainless steel	0,010	316 466

(1) For systems with control carriers use fixpoint hangers only.

Cable glands and terminal clamps for A1 & A2 boxes to be ordered separately (see cat. 8L). Control carriers with larger terminal box on request.



S 2 CONTROL CARRIER ACCESSORIES

acid
proof

Stain-
less

Brake for Control Carrier

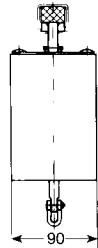
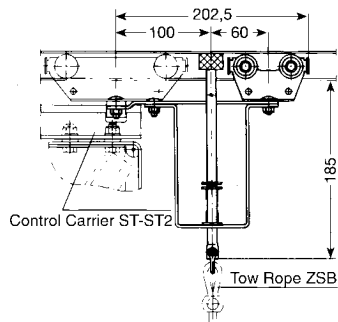

Type	Weight kg	Order-No.
BS 2	1,840	316 458

Carrier body: steel, galvanized
Wheels: steel ball bearings

Tow Rope and Grip for Brake BS 2

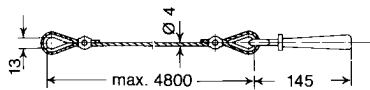

Type	Standard length- mm	Weight kg	Order-No.
ZSB	5000	0,250	310 850

Scope of supply: Grab handle, wire, 2 thimble, 2 cable clamps

Brake for Control Carrier with AC magnet (WM)

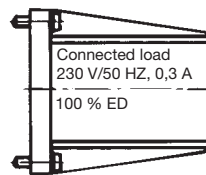
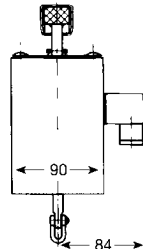
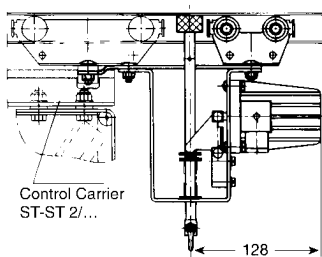

Type	Weight kg	Order-No.
BS 2-WM	3,000	316 457



S 2 motor powered
control carrier



S 2 CONTROL CARRIERS

with motorized lifting device for pushbutton station

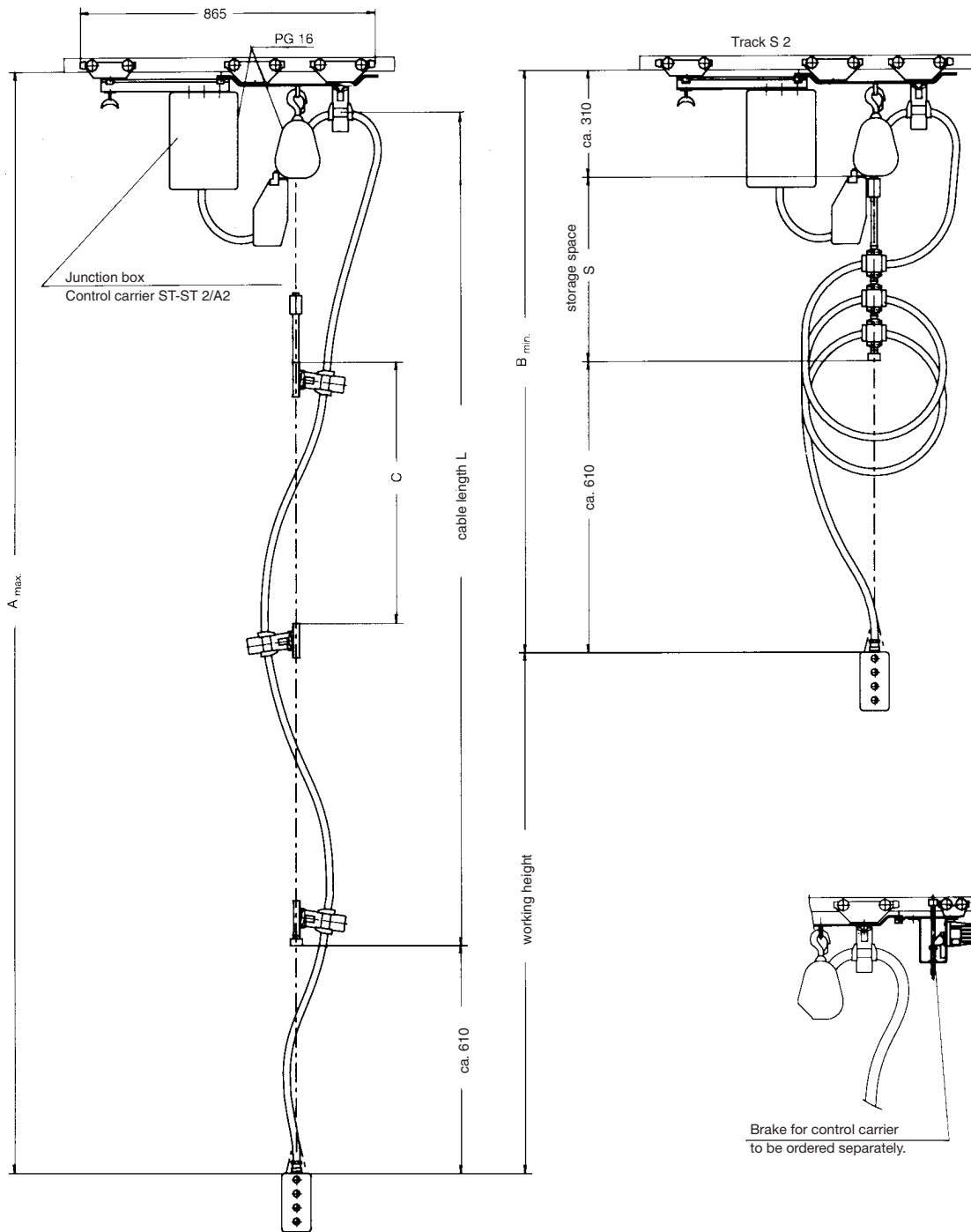

Brake for control carrier to be ordered separately.

cable length $L = (H+S) \times 1,05$ (m)
 attachment intervals $= \frac{L}{n}$ (m)
 storage distance $S = n \times 0,1 \text{ m} + 0,2 \text{ m}$ (m)

- H = working height (m)
- A_{max} = lowest position of pushbutton station (m)
- B_{min} = highest position of pushbutton station (m)
- S = storage distance (m)
- L = length of cable without connecting ends (m)
- C = attachment intervals of cable loops (m)
- n = number of cable loops

Type ⁽¹⁾	Working height H (m)	A max. (m)	B min. (m)	Storage distance S (m)	Number of cable loops (n)	Permissible load cable and push button station	Weight ca. kg	Order-No.
ST 2-H 1,3	1,30	2,55	1,25	0,33	1	52,000	18,000	316 560
ST 2-H 2,6	2,60	3,95	1,35	0,43	2	51,500	18,500	316 561
ST 2-H 3,9	3,90	5,35	1,45	0,53	3	51,000	19,000	316 562
ST 2-H 5,2	5,20	6,75	1,55	0,63	4	50,500	19,500	316 563
ST 2-H 6,5	6,50	8,15	1,65	0,73	5	50,000	20,000	316 564
ST 2-H 7,8	7,80	9,55	1,75	0,83	6	49,500	20,500	316 565
ST 2-H 9,1	9,10	10,95	1,85	0,93	7	49,000	21,000	316 566
ST 2-H 10,4	10,40	12,35	1,95	1,03	8	48,500	21,500	316 567
ST 2-H 11,7	11,70	13,75	2,05	1,13	9	48,000	22,000	316 568
ST 2-H 13,0	13,00	15,15	2,15	1,23	10	47,500	22,500	316 569

⁽¹⁾ Control carriers S 2 tracks use fixpoint hangers only.

Cable glands and terminal clamps to be ordered separately (see cat. 8L). Control carriers with larger terminal box on request.



S 2 CONTROL CARRIERS

Installation and Electrical Connection

1. Install the track per installation information, using fixpoint hangers only. Support distance in accordance to the load by control carrier, cable and pushbutton station.
2. Install the cable, including min. 3 control conductors (min. 1 mm²) to operate the lifting device as shown in the adjacent picture with the pushbutton station in the upper position. We recommend to use rubber sheathed round cable with tension relief core.
3. Mark the cable length $L = (H+S) \times 1,05$ (connecting ends to the pushbutton station and to the junction box non considered) in dimension C attachment intervals of cable loops (n).
4. Start with the first cable attachment clamp above the pushbutton station and continue to install the cable to the further attachment clamps in spiral loops at dim. C intervals (consider your cable connection length to the pushbutton).
5. Guiding the cable via the upper clamp attached to the control carrier you now enter the junction box and connect your cable to the terminal blocks.
6. The junction box must in addition be provided for 8 terminal blocks and 1 ground for the electrical connection of the lifting device.
7. The connection between the hoist and the junction box must be achieved via an 8-core plus ground cable of min. 1 mm² and in accordance to the adjacent wiring diagram.
8. Incoming power 380 V, 50 Hz, to be connected at L1, L2, L3, and ground and the control voltage 220 V, 50 Hz to the terminal clamps no. 2 and 3.
9. Wires at terminal clamps 1, 4, 5 represent connection to the keys S 1 and S 2 (up/down) in the pushbutton station.
10. The function key S 2 (down) can also be installed in an other position, for example in the crane cabin. 2 control conductors are then necessary to be provided via the cable festoon system.

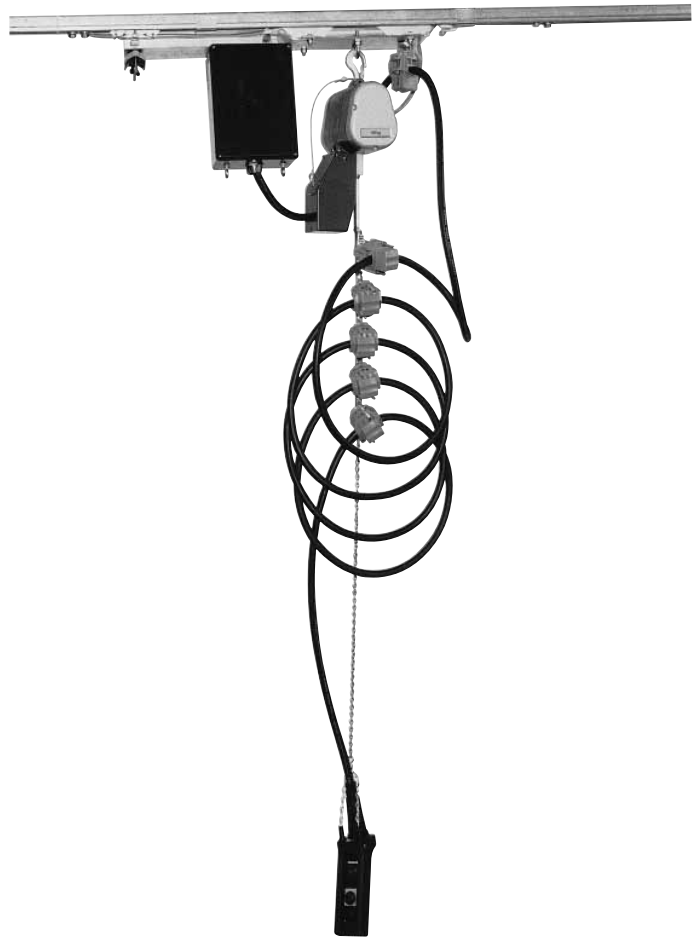

Commissioning and Adjustment of Limit Switch

11. The pushbutton station will lower automatically when pressing key S 2 (down).
12. The cable will form a spiral around the hoist chain and the pushbutton station will be rotating.
13. Once the pushbutton station has reached the lowest position the limit switch S 4 will switch off the hoist motor.
14. The 5% safety length guarantees a tension relief hanging down of the cable while the hoist chain is carrying the load of the pushbutton station. If this is not the case the limit switch in the chain box would have to be readjusted.
15. When pressing the function key S 1 (up) the pushbutton station will automatically move upward. Limit switch S 3 will switch off the movement.

Wiring diagram for motorized lifting device

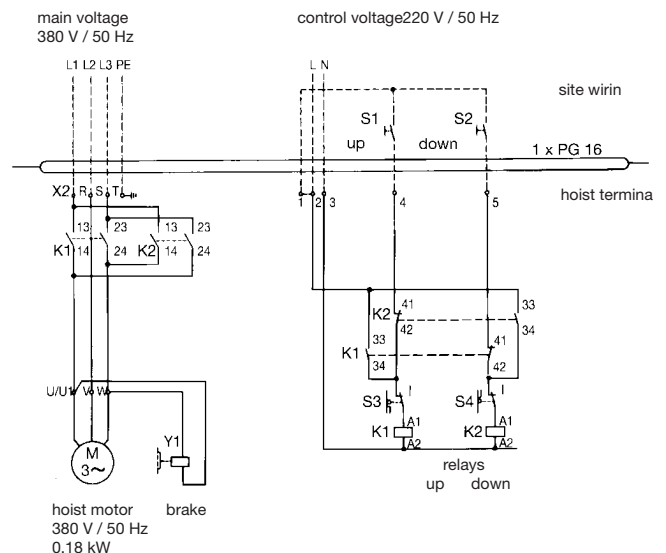

main voltage:	380 V, 50 Hz
control voltage:	220 V, 50 Hz
-----:	site wiring
S 1 and S 2:	key up/down, part of pushbutton station
S 3 and S 4:	limit switch up/down
K 1 and K 2:	relays up/down

For safety reasons and to completely secure the track joints we do recommend welding together the track and the joint clamps in the upper portion. Track and hangers at both ends of the system to be horizontally drilled 9 mm Ø and a hex. bolt M 8 x 60 mm, with nut and washer, pushed through to prevent the track from sliding.



S 3 TRACK AND ACCESSORIES

acid proof

Stain-less

Track

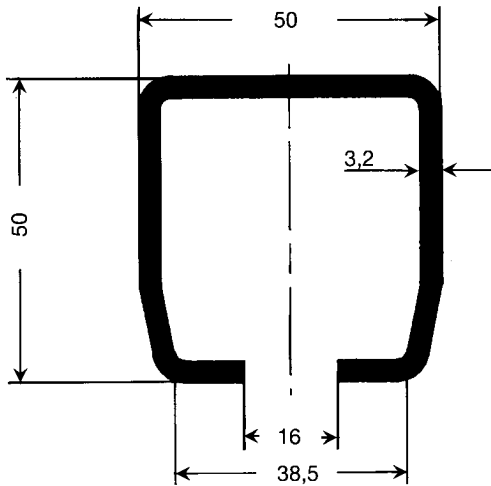

Type	S 3	S3A-G
Order-No. -in 6 m sections	314 126	314 246
Order-No. -surcharge for curves		
for carrier type	WST 3	
Material	steel, galvanized	1.4571
Supply length	6 m	
Standard support spacing	as per page 47, in straight systems max. 3 m in curves 1,5 m	
Moment of inertia Jx	16,9 cm ⁴	
Section Modulus Wx	6,1 cm ³	
Weight	4,050 kg/m	

Curves are available on request.

Hangers underhung

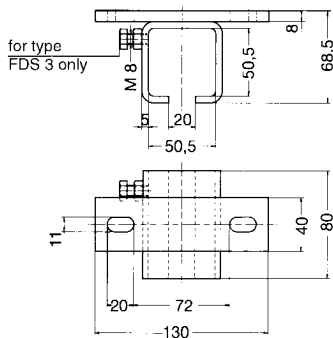

Type	Sliding hanger ADS 3	Fixpoint hanger FDS 3	Sliding hanger ADS 3-A2	Fixpoint hanger FDS 3-A2
Order-No.	314 014	314 013	314 283	314 284
Material	steel, galv.	steel, galv.	1.4301.	1.4301
Weight	0,920 kg	0,930 kg	0,920 kg	0,930 kg

Joint Clamp

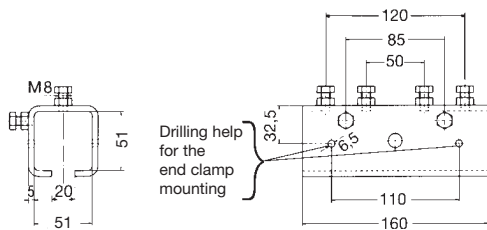

Type	VS 3	VS 3-A2
Order-No.	314 008	314 285
Material	steel, galvanized	1.4301
Weight	1,250 kg	1,250 kg

End Cap

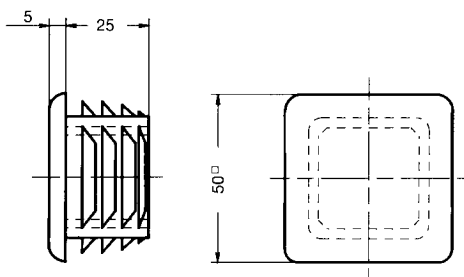

Type	KS 3
Order-No.	314 016
Material	polyethylene
Weight	0,020 kg



S 3 CABLE CARRIERS AND ACCESSORIES

- Steel type -



Cable Carriers or platform cables

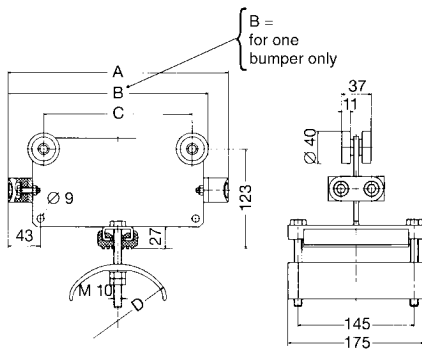

Engineering Data

Type	WST 3
Wheels	ball bearing sealed against dust and splash water, steel hardened, galvanized or with Polyurethane cover Temperature resistance Lub. grease of wheels: - 30° C to + 125° C Travelling speed: ca. 120 m/min.
Material	Carrier body: steel, galvanized Support saddle: light metal Bumper: Neoprene Hardware: galvanized Temperature resistance: - 30° C to +100° C
Max. cable load	max. 55 kg per carrier
Depth of cable loop	for curves max. 0,3 x track radius; consider tension relief

Type ⁽¹⁾	max. thckn. of individual cable mm	max. clamping capacity in mm height x width	A B C D				Weight kg	Order-No.	Order-No. Polyurethane wheels
			mm						
WST 3 F/175-100	12	30 x 135		175	110	100	2,130	314 018	314 077
WST 3 F/200-100	12	45 x 135	200		110	100	2,240	314 019	314 078
WST 3 F/200-140	14	25 x 135	200		110	140	2,420	314 020	314 079
WST 3 F/250-140	14	50 x 135		250	185	140	2,750	314 021	314 080
WST 3 F/250-170	17	35 x 135		250	185	170	3,480	314 022	314 081
WST 3 F/250-200	20	20 x 135		250	185	200	3,600	314 023	314 082
WST 3 F/275-140	14	60 x 135	275		185	140	2,840	314 024	314 083
WST 3 F/275-170	17	45 x 135	275		185	170	3,570	314 025	314 084
WST 3 F/275-200	20	30 x 135	275		185	200	3,680	314 026	314 085
WST 3 F/325-170	17	70 x 135		325	260	170	3,870	314 027	314 086
WST 3 F/325-200	20	55 x 135		325	260	200	4,020	314 028	314 087
WST 3 F/325-230	23	40 x 135		325	260	230	4,240	314 029	314 088
WST 3 F/350-200	20	70 x 135	350		260	200	4,110	314 030	314 089
WST 3 F/350-230	23	55 x 135	350		260	230	4,330	314 031	314 090

Lead Carriers for platform cables

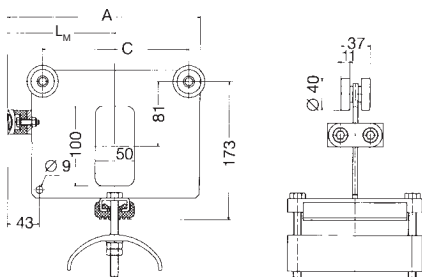

Type ⁽¹⁾	for Carrier type	A Lm C			Weight kg	Order-No.	Order-No. Polyurethane-Wheels
		mm					
MST 3 F/275-100	WST 3 F/175-100	244	138	185	2,720	314 032	314 091
	WST 3 F/200-100						
MST 3 F/275-140	WST 3 F/200-140	244	138	185	2,930	314 033	314 092
	WST 3 F/250-140						
	WST 3 F/275-140						
MST 3 F/275-170	WST 3 F/250-170	244	138	185	3,660	314 034	314 093
	WST 3 F/275-170						
MST 3 F/275-200	WST 3 F/250-200	244	138	185	3,770	314 035	314 094
	WST 3 F/275-200						
MST 3 F/325-170	WST 3 F/325-170	319	175	260	4,220	314 036	314 095
	WST 3 F/250-170						
MST 3 F/350-200	WST 3 F/325-200	319	175	260	4,360	314 037	314 096
	WST 3 F/350-200						
MST 3 F/350-230	WST 3 F/325-230	319	175	260	4,580	314 038	314 097
	WST 3 F/350-230						

Track Clamps for platform cables

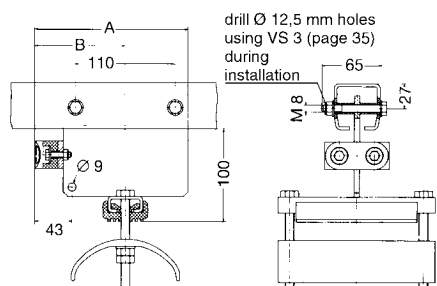

Type	for Carrier type	A L _E		Weight kg	Order-No.
		mm			
EST 3 F/200-100	WST 3 F/175-100	169	100	1,800	314 039
	WST 3 F/200-100				
EST 3 F/200-140	WST 3 F/200-140	169	100	1,970	314 040
EST 3 F/275-140	WST 3 F/250-140	244	138	2,390	314 041
	WST 3 F/275-140				
EST 3 F/275-170	WST 3 F/250-170	244	138	3,120	314 042
	WST 3 F/275-170				
EST 3 F/275-200	WST 3 F/250-200	244	138	3,240	314 043
	WST 3 F/275-200				
EST 3 F/325-170	WST 3 F/325-170	319	175	3,510	314 044
EST 3 F/350-200	WST 3 F/325-200	319	175	3,660	314 045
	WST 3 F/350-200				
EST 3 F/350-230	WST 3 F/325-230	319	175	3,880	314 046
	WST 3 F/350-230				



K 1 TRACK

acid
proof

Stain-
less

Extremely corrosive atmospheres (e. g. acid baths, galvanizing plants, sewage treatment plants, chemical plants etc.) require suitable materials.

The K1 track system, designed specifically for such applications, meets these special requirements.

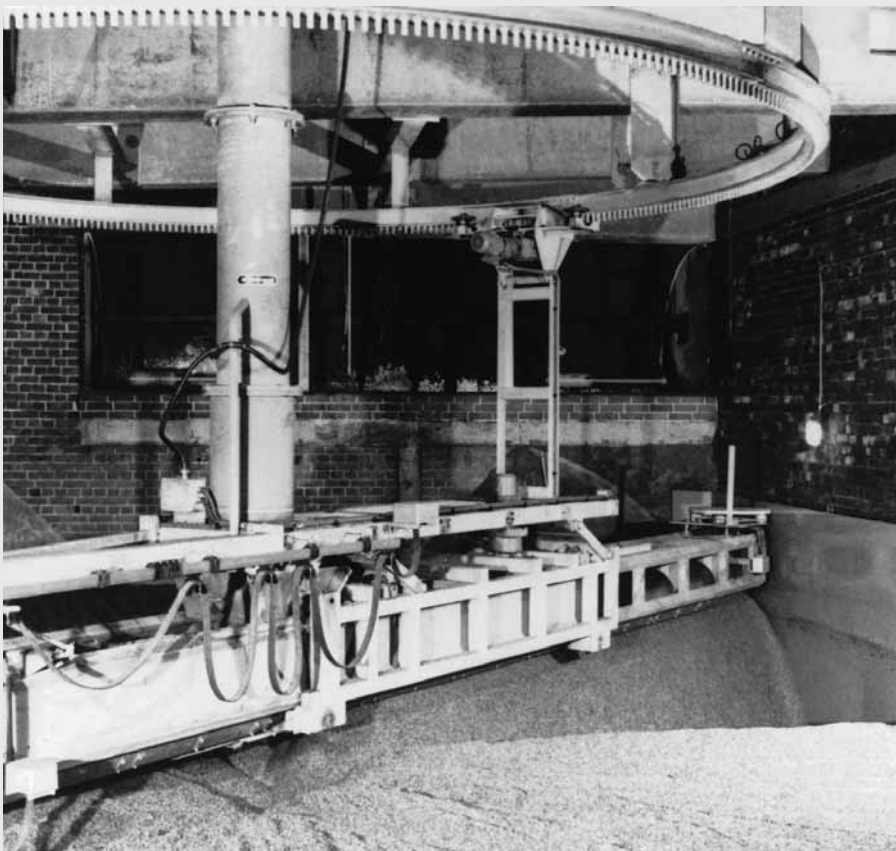

K 1 system in a malt factory



K 1 TRACK AND ACCESSORIES

acid
proof

Stain-
less

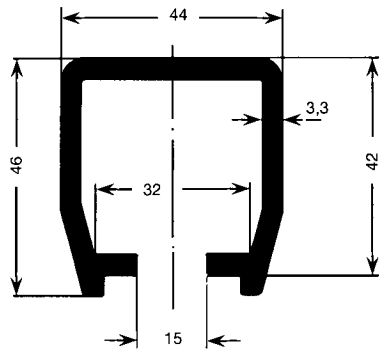

Tracks

Type	K1
Order-No. in 4 m sections	311 324
for Carriers type	SK 1 and WK 1
Material	Strong-PVC
Temperature resistance	- 30° C to + 55° C
Min. bending radius	1,5 m
Supply length	4 m
Standard support spacing	1 m, 0,5 m max. in curves
max. load	25 kg Support distance 1 m
Moment of inertia Jx	13,18 cm ⁴
Sections modulus Wx	5,18 cm ³
Weight	0,740 kg/m

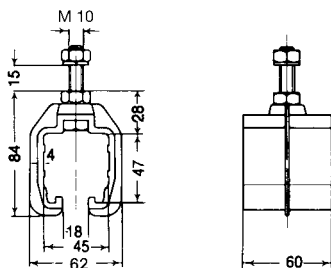

Sliding Hanger

Type	GK 1
Order-No.	311 020
Material	Polyethylene Hardware: stainless steel
max. load	25 kg
Weight	0,110 kg

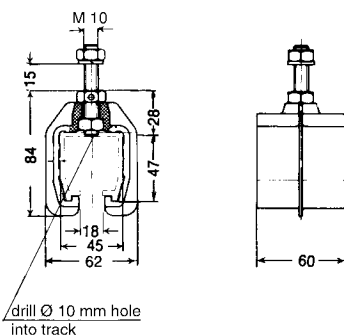

Fixpoint Hanger

Type	FK 1
Order-No.	311 030
Material	Polyethylene Hardware: stainless steel
max. load	25 kg
Weight	0,110 kg

Every installation requires one fixpoint hanger only in the center of the run. With control carriers use one additional each end.

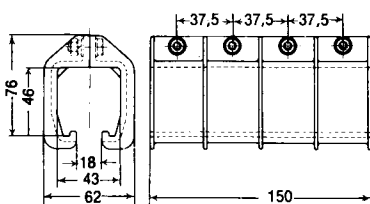

Joint Clamp

Type	VK 1
Order-No.	311 040
Material	Polyethylene Hardware: stainless steel
Weight	0,160 kg

End Cap

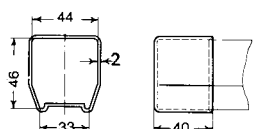

Type	K 1 E
Order-No.	312 170
Material	Polyethylene
Weight	0,010 kg



K 1 CABLE CARRIERS AND LEAD CARRIERS

acid proof

Stainless

Cable carrier – glider type -



Engineering Data – glider type

Type	SK 1 F
Max. system length	30 m
Material	Carrier body: HP-Polyethylene Support saddle: HP-Polyethylene Hardware: stainless steel Temperature resistance: - 30° C to + 80° C
Travelling speed	max. 50 m/min.
Max. load	max. 5 kg per glider

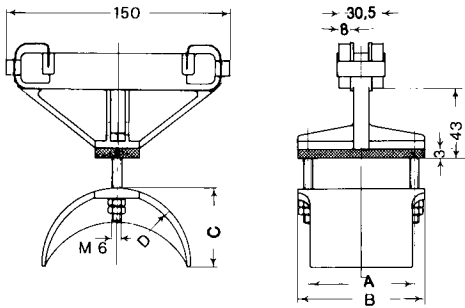

Cable Carrier – glider type – for flatform cable

Type	max. thckn. of individual cable mm	max. clamping capacity mm height x width	A B C D				Weight kg	Order-No.
			mm					
SK 1 F/150	12	25 x 65	71	85	52	100	0,210	311 050

Lead Carrier – glider type – for flatform cable

Type	for Glider type	Weight kg	Order-No.
MSK 1 F/150	SK 1 F/150	0,220	311 060

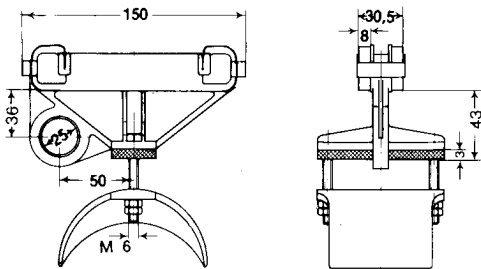

Cable Carrier – roller type –

Engineering Data – roller type



Type	WK 1 F
Wheels	Polyethylene rollers on bushed bearings
Travelling Speed	max. 60 m/min.
Material	Carrier body: stainless steel Wheels: Polyethylene Support saddle: stainless steel Hardware: stainless steel Temperature resistance: - 30° C to + 80° C
Max. load	max. 10 kg per carrier
Loop depth	for curves max. 0,3 x track radius, consider tension relief

Cable Carrier – roller type – for flatform cable

Type	max. thckn. of individual cable mm	max. clamping capacity mm height x width	A B C D				Weight kg	Order-No.
			mm					
WK 1 F/100 n	8	25 x 65	100	55	25	50	0,420	311 210
WK 1 F/150 n	12	25 x 65	150	95	50	100	0,510	311 180

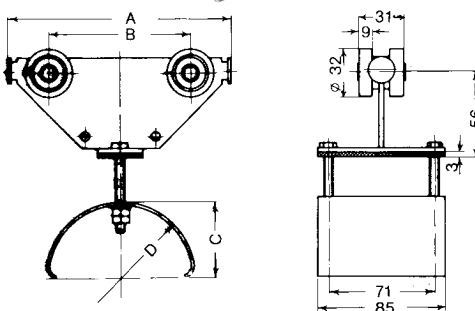



K 1 LEAD CARRIERS AND ACCESSORIES

acid proof

Stainless

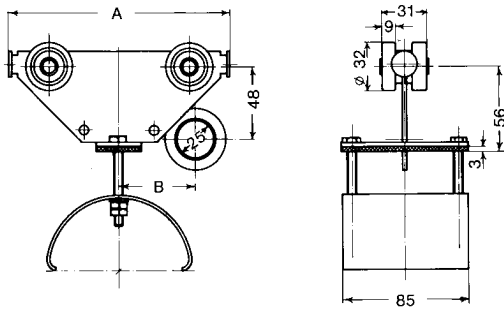

Lead Carriers – roller type – for flatform cables

Type	for Carrier type	A	B	Weight kg	Order-No.
		mm			
MK 1 F/100 n	WK 1 F/100 n	100	45	0,450	311 220
MK 1 F/150 n	WK 1 F/150 n	150	55	0,540	311 190

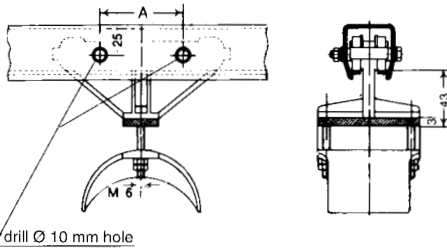

Track Clamps for flatform cables

LE = 125 mm with strain relief and stop
LE = 75 mm without strain relief

Type	for Glider and Carrier type	A mm	Weight kg	Order-No.
ESK 1 F/150	SK 1 F/150	70	0,220	311 070
EK 1 F/100 n	WK 1 F/100 n	55	0,370	311 230
EK 1 F/150 n	WK 1 F/150 n	95	0,500	311 200

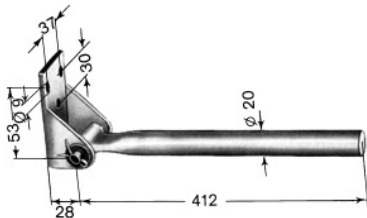

Tow arm

Type	GKM	GKM/K
Material	steel, galvanized	stainless steel
Weight	0,620 kg	0,620 kg
Order-No.	260 350	261 560

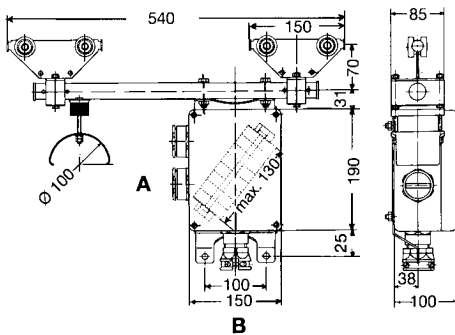

Control Carrier

Type ⁽¹⁾	max. thickn. of individual cable mm	max. clamping capacity mm height x width	max. carrying capacity kg	Weight kg	Order-No.
ST-K 1	12	25 x 65	20	2,800	311 110

Cable glands and terminal clamps to be ordered separately (see cat. 8L).

Cable glands	max. number A-Side	max. number B-Side	Cable glands	max. number A-Side	max. number B-Side
M 20 x 1,5	6	2	M 40 x 1,5	2	1
M 25 x 1,5	5	2	M 50 x 1,5	2	1
M 32 x 1,5	3	1	M 63 x 1,5	-	-

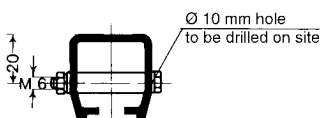

Bumper stop

Type	PK 1
Material	PVC
Hardware	stainless steel
Weight	0,020 kg
Order-No.	311 170

⁽¹⁾ Control Carrier tracks use one fixpoint hanger each in the center and at both ends of the run. The rest in sliding hangers.



K 1 CABLE CARRIERS AND ACCESSORIES – Steel swivel type –

acid proof

Stainless

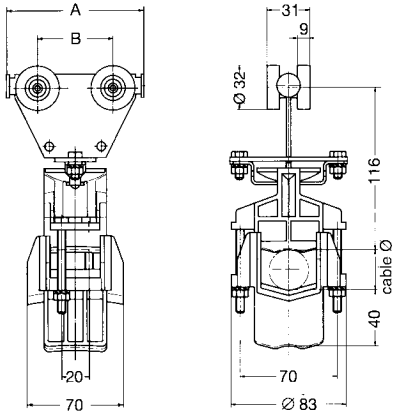

Engineering Data

Type	WK 1 R
Wheels	Polyethylene rollers on bushed bearings
Travelling speed	60 m/min.
Material	Carrier body: stainless steel Wheels: Polyethylene Support saddle: Polypropylene Hardware: stainless steel Temperature resistance: - 10° C to + 80° C
max. cable load	max. 10 kg per carrier
Depth of cable loop	for curves max. 0,3 x track radius, consider tension relief

Cable Carriers for round cables and hoses

Type	Cable Ø	A	B	Weight kg	Order-No.
		mm			
WK 1 R/100	5 mm to 38 mm	100	55	0,420	311 308
WK 1 R/150		150	95	0,470	311 309

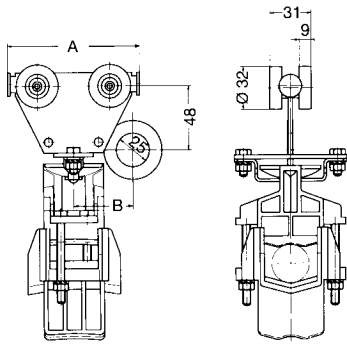

Lead Carriers for round cables and hoses

Type	for Carrier type	A	B	Weight kg	Order-No.
		mm			
MK 1 R/100	WK 1 R/100	100	45	0,450	311 310
MK 1 R/150	WK 1 R/150	150	55	0,500	311 311

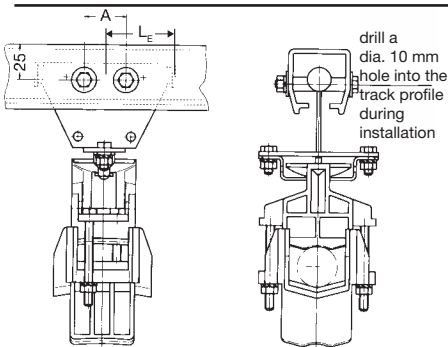

Track Clamps for round cables and hoses

Type	for Carrier type	LE	A mm	Weight kg	Order-No.
EK 1 R/100	WK 1 R/100	50	55	0,370	311 312
EK 1 R/150	WK 1 R/150	75	95	0,420	311 313

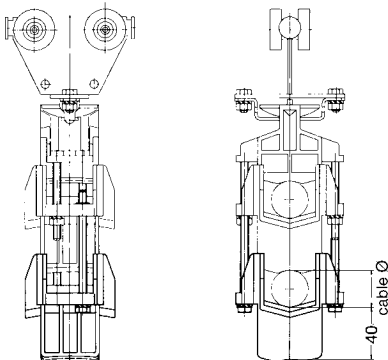

Support saddle for round cables and hoses for additional tiers

Type	for Carrier type	Weight kg	Order-No.
LAR-E	WK 1 R (all types)	0,110	312 532



TENSION RELIEF

Chains for WST 1 and WST 2 carriers

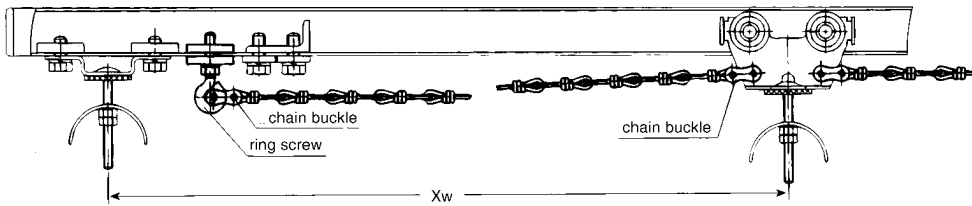

How to determine length of chain

Type	2 x 22	2 x 22 E
Order-No.	316 803	316 873
Material	steel	steel
Wire-Ø mm	2	2
Link size mm	22	22
Protection	galvanized	-
Weight kg/m	0,075	0,075

$$X_w = \frac{S + SP}{n} \times 1,05$$

X_w = Distance c/c carriers with chain stretched mm
 S = Fahrweg in mm
 SP = Travel distance mm
 n = Number of loops

Zubehör:

Each piece of chain requires: 2 chain buckles type KSS⁽¹⁾, Cat.-No. 360 028.
 Each track clamp requires: 1 ring screw type RS 1-2, Cat.-No. 312 827.

Steel Tow Ropes for WST 3 Carriers

Standard steel rope with fibreglass reinforcing
 Type Z 4 galvanized; Type Z 4 - PVC additionally PVC shrouded complete, cut to suit the application, incl. rope clamps, thimbles and shackles.

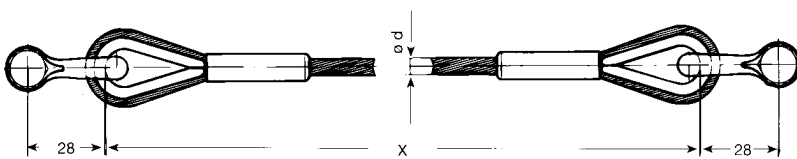

Length of Tow Rope mm	Z 4 d = 6 mm	Z 4-PVC d = 6/8 mm
	Order-No.	
up to 2000	346 372	346 383
2001- 3000	346 373	346 384
3001- 4000	346 374	346 385
4001- 5000	346 375	346 386
5001- 6000	346 376	346 387
6001- 7000	346 377	346 388
7001- 8000	346 378	346 389
8001- 9000	346 379	346 390
9001-10000	346 380	346 391
10001-11000	346 381	346 392
11001-12000	346 382	346 393

Please specify with your order:
 Tow Rope: Type
 Length of tow rope X: mm
 Order-No.:

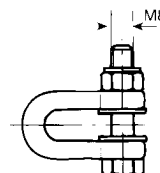

How to determine length of rope

$$X = \frac{S \cdot (f - 0,1) + Z}{n} + 2 Y$$

X = Length of tow rope mm
 S = Travel distance mm
 f = Cable safety factor (e.g. $\geq 1,15$)
 Z = Open space (min. 1 carrier) mm
 n = Number of loops
 Y = Projecting bumper mm (see table)

Bumper projection:	
Carrier Type	Y in mm
WST 3 (1 bumper)	3
WST 3 (2 bumper)	15



TYPICAL APPLICATIONS AND HOW TO ORDER

- cables & fittings see cat. 8 L -

S 1 Track System (flat cable)

Application: Electric hoist, outdoors with separate supply system for pendant control

Current load:	11 kW
Voltage:	380 V, 50 Hz
Required control cable:	7 x 1,5 mm ²
Travel distance:	28 m
Perm. depth of loops:	1 m
Travel speed:	35 m/min

How to select the correct cable festoon system:

1. Take ampere load from cat. 8 L	22,5 A
2. Select suitable cables (cat. 8 L)	For main current: Neoprene flatform cable 4 x 2,5 mm ² , dimensions: 8,2 x 24 mm For control current: Neoprene flatform cable 8 x 1,5 mm ² , dimensions: 6,4 x 32 mm
3. Select cable carrier, see page 10	WS 1 F/85-PM
4. Cable safety length, see page 48	f = 1,1
5. Determine number of cable loops, diagram page 49	17
6. Determine storage distance, formula page 48 SP = 17 x 85 mm + 85 mm	= min. 1530 mm
7. Determine length of cable, formula page 48 L = (28 m + 1,53 m) x 1,1 = 32,48 m + 2 x 1 m hookup ends	= 35 m
8. Control carrier, see page 18	ST-ST 1/A1

Material to order:	Typ	Order-No.
2 x 30 m Track (10 lengths of 6 m)	S1	312 946
2 x 17 Fixpoint hangers ⁽¹⁾	FAS 1	310 500
2 x 17 Pair of Bolts	M 8 x 25	310 510
2 x 4 Joint clamps	VS 1	310 050
2 x 2 End caps	K 30	360 023
2 x 16 Cable carriers	WS 1 F/85-PM	312 689
1 Lead carrier	MS 1 F/85-PM	312 692
2 x 1 Track clamp	ES 1 F/85-PM	312 693
3 Bumper stops	PS 1-1	312 605
1 Control carrier	ST-ST 1/A1	312 695
c/w:		
7 Terminal clamps	SAK 2,5	330 800
1 Terminal clamp for ground	EK 2,5 NPA	331 283
1 End plate	APPA 2,5	331 278
2 End angles	EWK 1	331 288
A-Seite: 1 flat cable gland for 8 x 1,5 mm ²	M 50 x 1,5-1	332 552
1 counter nut	M 50 x 1,5	332 535
B-Seite: 1 round cable gland for 8 x 1,5 mm ²	M 25 x 1,5	332 539
1 counter nut	M 25 x 1,5	332 533
1 Brake spring	BF 1	310 860
2 flat cable glands for 4 x 2,5 mm ²	M 32 x 1,5-1	332 550
2 counter nut	M 32 x 1,5	332 534
1 flat cable gland for 8 x 1,5 mm ²	M 50 x 1,5-1	332 552
1 counter nut	M 50 x 1,5	332 535

⁽¹⁾ Consider permissible track area load (see diagram page 47).



TYPICAL APPLICATIONS AND HOW TO ORDER

- cables & fittings see cat. 8 L -

S 1 Track System (spiral looped round cable)

Application: Power supply to welding machine

Cable:	2 round cables Ø 25 mm 1 hose Ø 22 mm
Travel distance::	42 m
Perm. depth of loops::	1,7 m
Travel speed:	max. 30 m/min

How to select the correct cable festoon system:

1. Selection of carriers, see page 15	WST 1 R/125
2. Additional support saddles, see page 15	LAR
3. Cable safety length, see page 48	f = 1,2
4. Determine number of cable loops, diagram page 51	15
5. Determine storage distance, formula page 48 SP = 15 x 125 mm + 125 mm	= min. 2000 mm
6. Determine length of cable/hose, formula page 48 L = (42 m + 2 m) x 1,2 = 52,8 m + 2 x 3 m hookup ends	= 59 m

Material to order:	Type	Order-No.
45 m Track (7 lengths of 6 m, 1 length of 3 m)	S 1, 6 m	312 956
	S 1, 3 m	312 953
2 Fixpoint hangers ⁽¹⁾	FDS 1	310 430
22 Sliding hangers ⁽¹⁾	ADS 1	310 370
7 Joint clamps	VS 1	310 050
2 End caps	K 30	360 023
14 Cable carriers	WST 1 R/125	312 493
1 Lead carrier	MST 1 R/125	312 497
1 Track clamp	EST 1 R	312 498
32 Support saddles	LAR	312 500
1 Bumper stop	PS 1	310 300





TYPICAL APPLICATIONS AND HOW TO ORDER

- cables & fittings see cat. 8 L -

S 2 Track System (flat cables)

Application: Current supply system for crane trolley indoors

Cables:	2 flatform 4 x 16 mm ² 4 flatform 12 x 2,5 mm ²
Travel distance:	35 m
Perm. depth of loops:	1,8 m
Travel speed	80 m/min

How to select the correct cable festoon system:

1. Select cable carrier, see page 26	WST 2 FR/200-140 B175P
2. Cable safety length, see page 48	f = 1,15
3. Determine number of cable loops, diagram page 50	12
4. Determine storage distance, formula page 48 SP = 12 x 200 mm + 200 mm	= min. 2600 mm
5. Determine length of cable, formula page 48 L = (35 m + 2,6 m) x 1,15 = 43,24 m + 2 x 4 m hookup ends	= 52 m

Material to order:	Typ	Order-No.
38 m Track (6 x 6 m, 1 x 2 m)	S 2, 6 m	312 636
	S 2, 2 m	312 632
2 Fixpoint hangers ⁽¹⁾	FDS 2	315 210
24 Sliding hangers ⁽¹⁾	ADS 2	315 200
6 Joint clamps	VS 2	315 050
2 End caps	K 40	316 449
11 Cable carriers	WST 2 FR/200-140 B175P	316 911
1 Lead carrier	MST 2 FR/200-140 B175P	316 960
1 Track clamp	EST 2 FR/140 B175	316 990
1 Bumper stop	PS 2-1 G	317 001
2 x 52 m PVC-flatform cable (N)	H07 VV H6-F 4 G 16	331 362
4 x 52 m PVC-flatform cable (N)	H07 VV H6-F 12 G 2,5	331 358
4 Flat cable glands for 4 x 16 mm ²	M 50 x 1,5-2	332 553
4 Counter nuts	M 50 x 1,5	332 535
8 Flat cable glands for 12 x 2,5 mm ²	M 63 x 1,5-1	332 554
8 Counter nuts	M 63 x 1,5	332 542

K1 Track System (flat cables)

Application: Current supply system for a malt factory (high humidity)

Cables:	1 flatform 4 x 10 mm ² 3 flatform 8 x 1,5 mm ²
Travel distance:	50 m
Perm. depth of loops:	1 m
Travel speed:	20 m/min

How to select the correct cable festoon system:

1. Select cable carrier, see page 38	WK 1 F/150 n
2. Cable safety length, see page 48	f = 1,1
3. Determine number of cable loops, diagram page 49	29
4. Determine storage distance, formula page 48 SP = 29 x 150 mm + 150 mm	= min. 4,5 m
5. Determine length of cable, formula page 48 L = (50 m + 4,5 m) x 1,1 = 59,95 m + 2 x 2 m connection ends	= 64 m

Material to order:	Typ	Order-No.
55 m Track (13 x 4 m, 1 x 3 m)	K 1, 4 m	311 324
	K 1, 3 m	311 323
13 Joint clamps	VK 1	311 040
59 Sliding hangers ⁽²⁾	GK 1	311 020
1 Fixpoint hanger ⁽²⁾	FK 1	311 030
2 End caps	K 1 E	312 170
28 Cable carriers	WK 1 F/150 n	311 180
1 Lead carrier	MK 1 F/150 n	311 190
1 Tow arm	GKM/K	311 301
1 Track clamp	EK 1 F/150 n	311 200
64 m PVC-flatform cable (N)	H07 VV H2-F 4 G 10	331 361
3 x 64 m PVC-flatform cable (N)	H07 VV H2-F 8 G 1,5	331 354

⁽¹⁾ Consider permissible track area load (see diagram page 47).

⁽²⁾ Permissible load (25 kg) of hangers to be considered.



SYSTEM LAYOUT

Engineering Data

Cable Specification

Travel distance	S =	m	Number of cables	Cable type	Dimension mm	Weight kg/m	Total weight kg/m
Travel speed	V =	m/min					
Acceleration	a =	m/s ²					
Loop depth	h =	m					
Storage distance	SP =	m					
Open space	Z =	m					
Cable safety factor	f =						
Number of loops	n =						
Cable carrier	Typ						
Length of carrier	l =	m					
Diameter of support saddle	D =	m					
Weight of carrier	Gw =	kg					
Track	Typ						
Weight of track	Gs =	kg/m	Total Weight of all cables per meter GL =				

Layout of the system

1. Number of loops (see diagram or formula) (At Z = 0)

$n = \frac{f \times S}{2h - f \times l + 1,254 D} = \frac{x}{2x - x + 1,254 x} =$		determined
---	--	------------

2. Loop depth (see diagram or formula)

$h = \frac{f}{2} \left(\frac{S}{n} + l \right) - 0,627 \times D = \frac{\quad}{2} \left(\quad + \quad \right) - 0,627 \times \quad =$		m
---	--	---

3. Storage distance (center track clamp to center lead carrier)

$SP = n \times l + Z = \quad \times \quad + \quad =$		m
--	--	---

4. Cable length

Cable length w/o hookup endsen $L = (S + SP) \times f = (\quad + \quad) \times \quad =$		m
Hookup length – track clamp side	LE =	m
Hookup length – lead carrier side	LM =	m
Total cable length	L ges. =	m

5. Cable weight per carrier

$GLW = \frac{L}{n} \times GL = \quad \times \quad =$		kg
--	--	----

6. Load on track per meter

$GM = \frac{GLW + Gw}{l} + Gs = \quad + \quad =$		kg/m
--	--	------

7. Support spacing for track

see diagram page 47	Support spacing / A =	m
---------------------	-----------------------	---



SUPPORT SPACING FOR BOX TRACKS

S 1 A - S 1 - S 1 E - S 2 - S 2 E - S 3

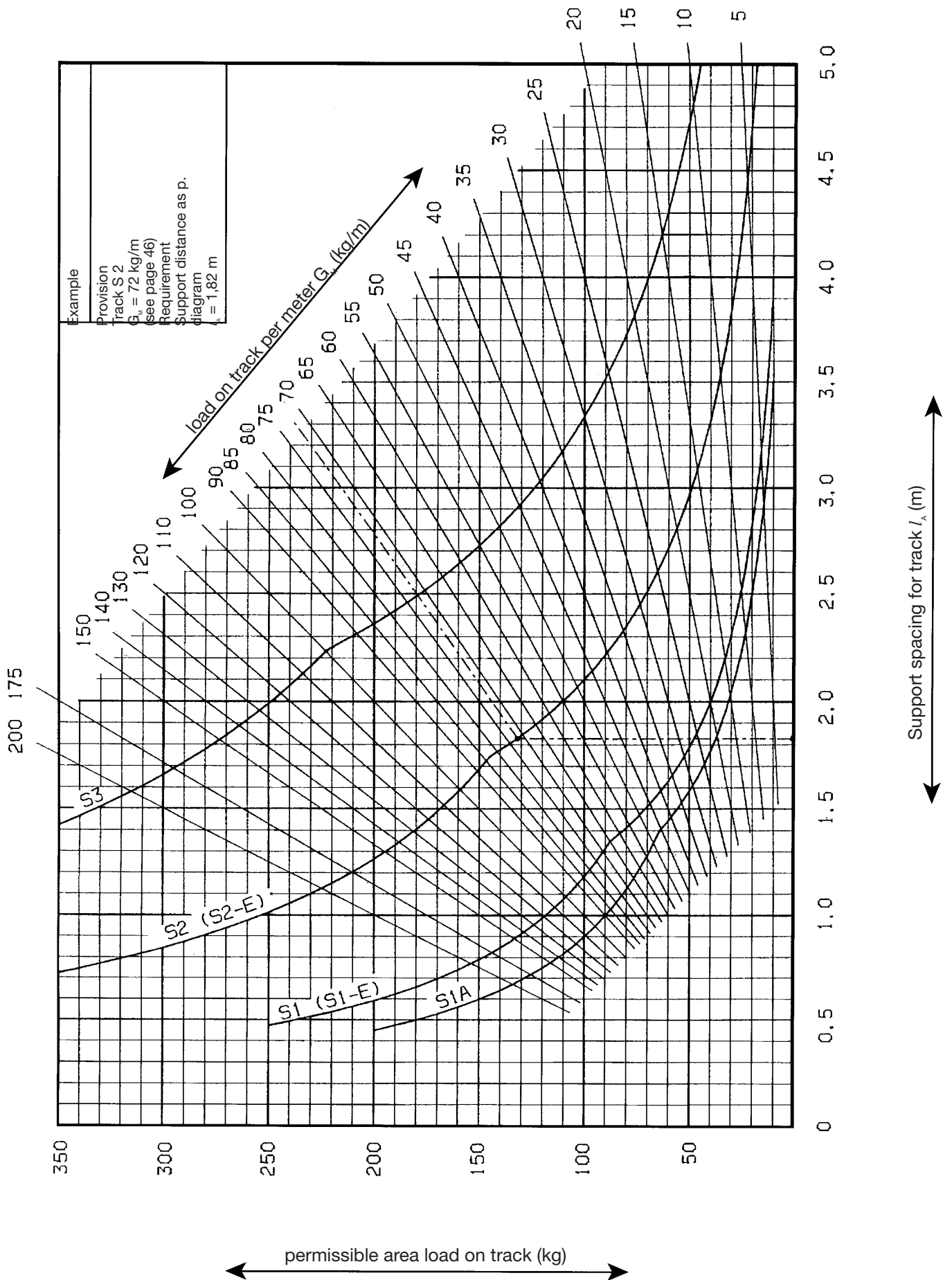



HOW TO DETERMINE

Number and Depth of Loops, Storage Distance, Cable Length, Number of Carriers

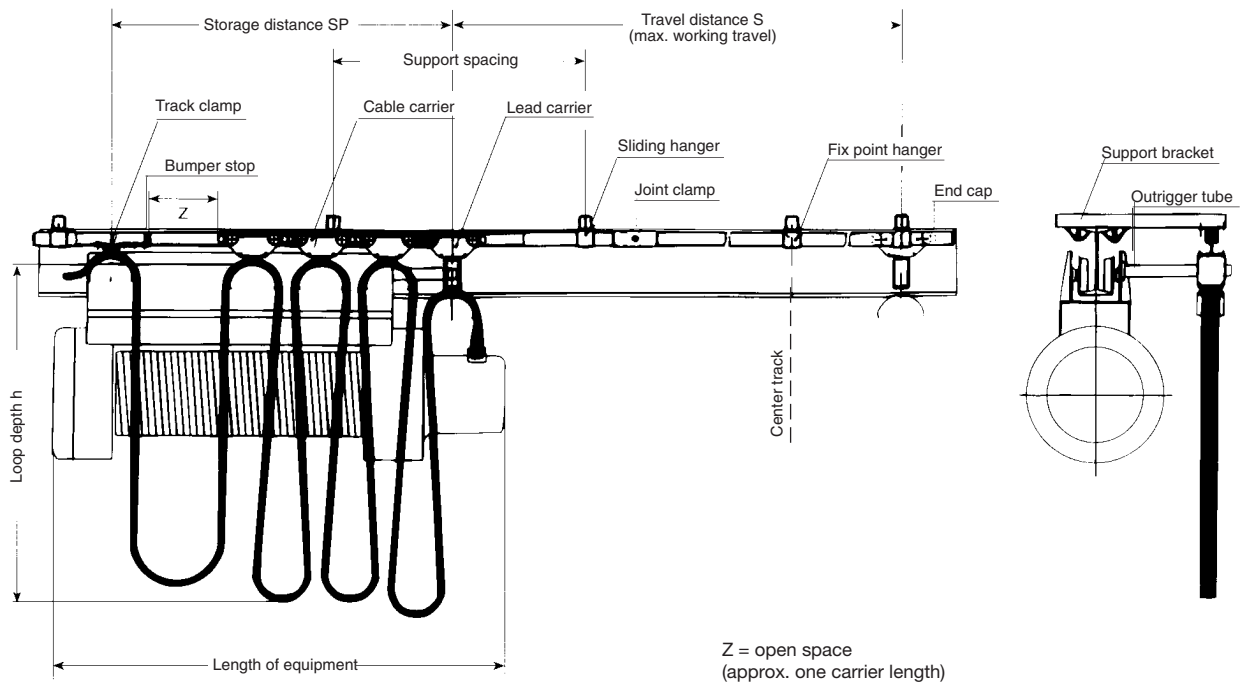

Cable Safety Length Directions

Travel Speed	cable loop depth	safety factor
up to 35 m/min	more than 0,3 m	f = 1,1
up to 50 m/min	up to 0,8 m	f = 1,15
up to 50 m/min	more than 0,8 m	f = 1,1
up to 80 m/min	up to 0,8 m	f = 1,2
up to 80 m/min	more than 0,8 m	f = 1,15
for spiral looped round cable		f = 1,2

For higher speed factors please consult factory.

Number of loops

$$n = \frac{f \times S}{2h - f \times l + 1,254 D}$$

Cable loop depth

$$h = \frac{f}{2} \left(\frac{S}{n} + l \right) - 0,627 \times D$$

Storage distance

$$SP = n \times l + Z$$

Cable length

(c/c track clamp – lead carrier without hookup ends)

$$L = (S + SP) \times f$$

Number of Carriers

(without lead carrier and track clamp)

$$= n - 1$$

- S = Travel distance (m)
- h = Cable loop depth (m)
- SP = Storage distance (m)
- Z = Open space (min. one carrier length)
- n = Number of loops
- l = Length of carrier (m)
- D = Diameter of support saddle (m)
- f = Cable length safety factor



CABLE LOOPS

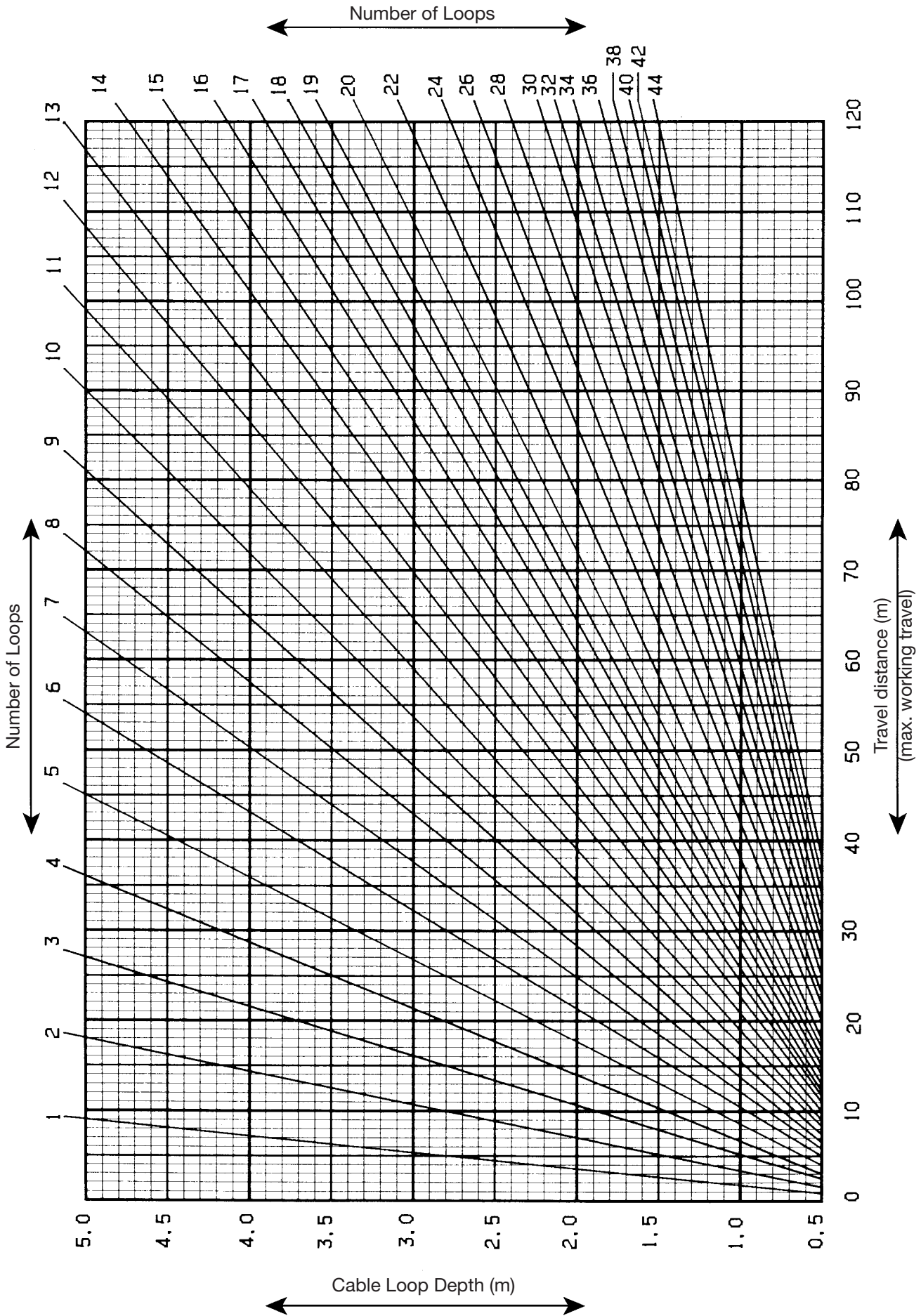

The diagram considers a cable length safety factor of $f = 1.1$



CABLE LOOPS

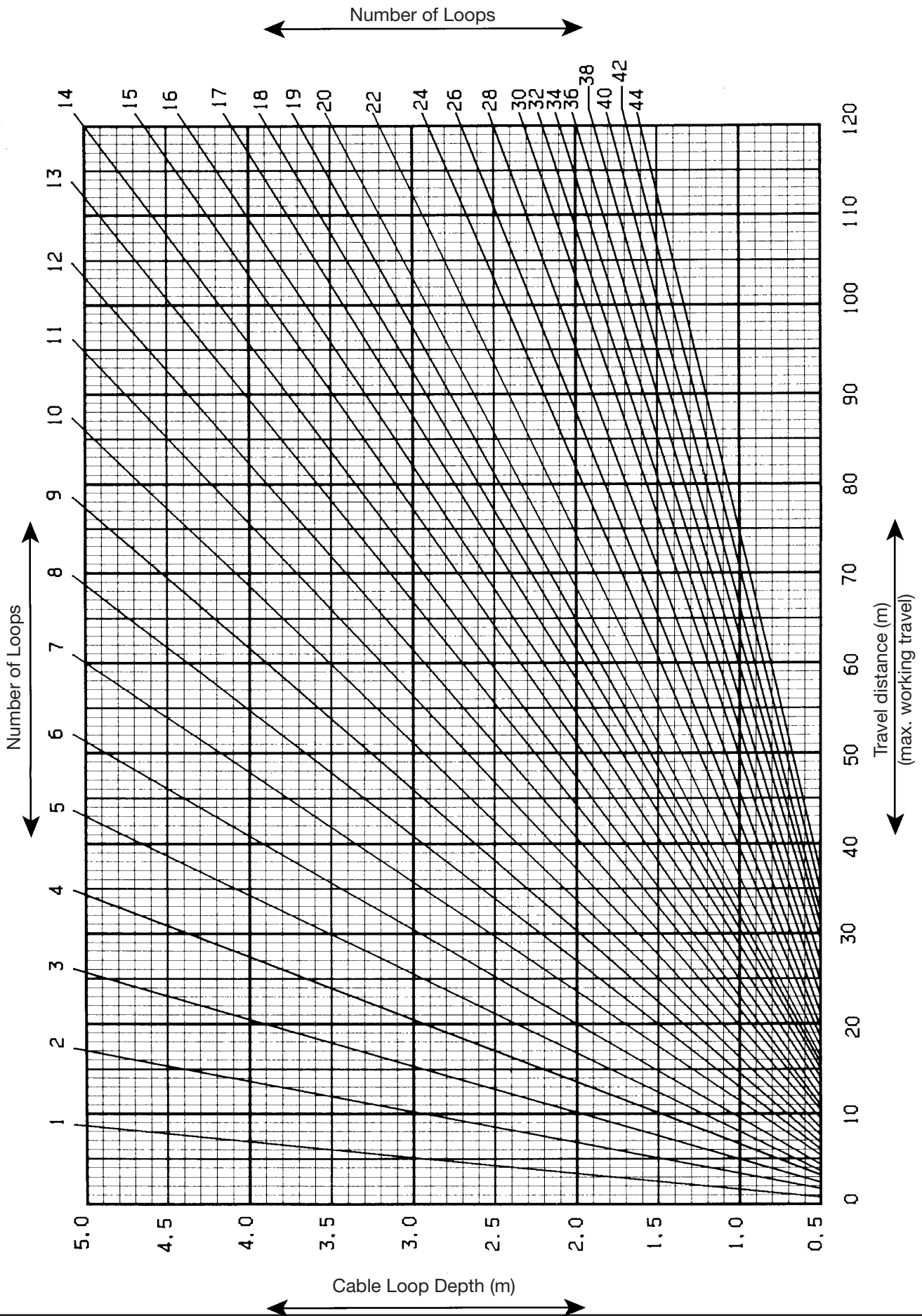

The diagram considers a cable length safety factor of $f = 1.15$



CABLE LOOPS

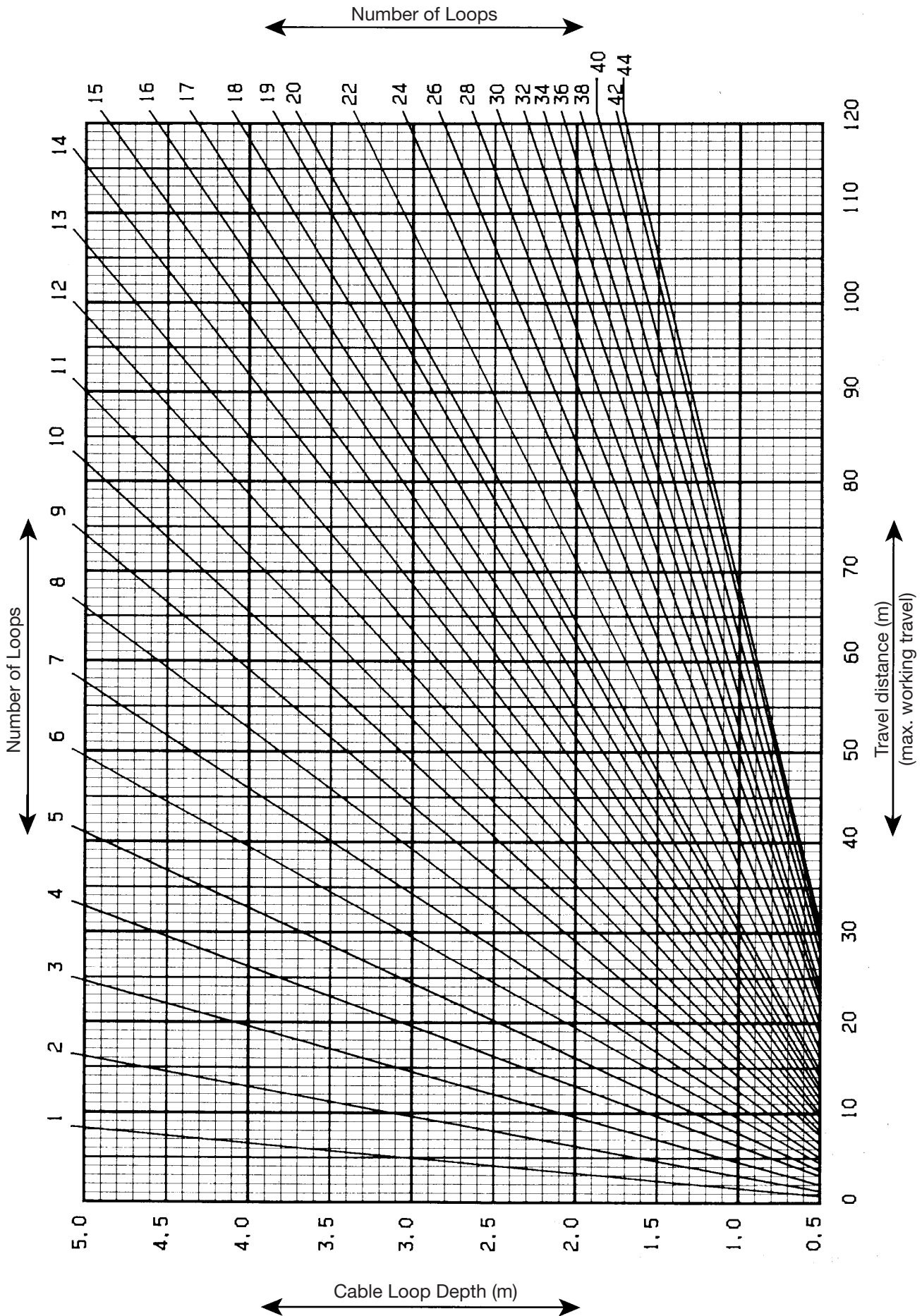

The diagram considers a cable length safety factor of $f = 1.2$



Products and Service

Catalog no.

Powerails	1 a
Battery Charging Systems	1 b
Insulated Powerails U 10	2 a
Insulated Powerails U 20 - U 30 - U 40	2 b
Insulated Powerails U 15 - U 25 - U 35	2 c
Aluminum Enclosed Conductor Systems LSV - LSVG	3 a
Powerail Enclosed Conductor Systems KBSL - KSL - KSLT	4 a
Powerail Enclosed Conductor Systems VKS - VKL	4 b
Powerail Enclosed Conductor Systems MKLD - MKLF - MKLS	4 c
Powerail Enclosed Conductor Systems VKS 10	4 d
Powerail Enclosed Conductor Systems KBH	4 e
Heavy Enclosed Conductor Systems	5
Trolley Wire and Accessories	6
Cable Tenders	7
Cable Carriers for □ tracks	8 a
Cable Carriers for Flatform Cables on I beams	8 bF
Cable Carriers for Round Cables on I beams	8 bR
Cable Carriers and Accessories for ◇ tracks	8 c
Conductor Cables and Fittings	8 L
Spring Operated Cable Reels	9 a
VAHLE POWERCOM® Digital Transmission Systems	9 c
CPS® Contactless Power Supply	9 d
SMG - Slotted Microwave Guide	9 e
Position Encoding Systems	9 f
Motor Powered Cable Reels	10
Installations/Commissioning	
Spare Parts/Maintenance Service	





Products and Service

Catalog no.

Copperhead Conductor Systems	1 a
Battery Charging Systems	1 b
Insulated Powerails U 10	2 a
Insulated Powerails U 20 - U 30 - U 40	2 b
Insulated Powerails U 15 - U 25 - U 35	2 c
Aluminum Enclosed Conductor Systems LSV - LSVG	3 a
Powerail Enclosed Conductor Systems KBSL - KSL - KSLT	4 a
Powerail Enclosed Conductor Systems VKS - VKL	4 b
Powerail Enclosed Conductor Systems MKLD - MKLF - MKLS	4 c
Powerail Enclosed Conductor Systems VKS 10	4 d
Powerail Enclosed Conductor Systems KBH	4 e
Heavy Enclosed Conductor Systems	5
Trolley Wire and Accessories	6
Cable Tenders	7
Cable Carriers for □ tracks	8 a
Cable Carriers for Platform Cables on I beams	8 bF
Cable Carriers for Round Cables on I beams	8 bR
Cable Carriers and Accessories for ◇ tracks	8 c
Conductor Cables and Fittings	8 L
Spring Operated Cable Reels	9 a
VAHLE POWERCOM® Digital Transmission Systems	9 c
CPS® Contactless Power Supply	9 d
SMG - Slotted Microwave Guide	9 e
Position Encoding Systems	9 f
Motor Powered Cable Reels	10
Installations/Commissioning	
Spare Parts/Maintenance Service	



POWERAIL LTD.

WORKING FOR THE FUTURE WITH



Powerail Ltd. High Road, Finchley, London, N12 8PT,
Phone 020 8446 0350/1246 • Fax 020 8446 7054
E-mail: enquiries@powerailtld.com



Products and Service

Catalog no.

Copperhead Conductor Systems	1 a
Battery Charging Systems	1 b
Insulated Powerails U 10	2 a
Insulated Powerails U 20 - U 30 - U 40	2 b
Insulated Powerails U 15 - U 25 - U 35	2 c
Aluminum Enclosed Conductor Systems LSV - LSVG	3 a
Powerail Enclosed Conductor Systems KBSL - KSL - KSLT	4 a
Powerail Enclosed Conductor Systems VKS - VKL	4 b
Powerail Enclosed Conductor Systems MKLD - MKLF - MKLS	4 c
Powerail Enclosed Conductor Systems VKS 10	4 d
Powerail Enclosed Conductor Systems KBH	4 e
Heavy Enclosed Conductor Systems	5
Trolley Wire and Accessories	6
Cable Tenders	7
Cable Carriers for □ tracks	8 a
Cable Carriers for Flatform Cables on I beams	8 bF
Cable Carriers for Round Cables on I beams	8 bR
Cable Carriers and Accessories for ◇ tracks	8 c
Conductor Cables and Fittings	8 L
Spring Operated Cable Reels	9 a
VAHLE POWERCOM® Digital Transmission Systems	9 c
CPS® Contactless Power Supply	9 d
SMG - Slotted Microwave Guide	9 e
Position Encoding Systems	9 f
Motor Powered Cable Reels	10
Installations/Commissioning	
Spare Parts/Maintenance Service	

